

# SNEED PACK

SNEED-PACK Round Bottle Label  
Machine - Tabletop

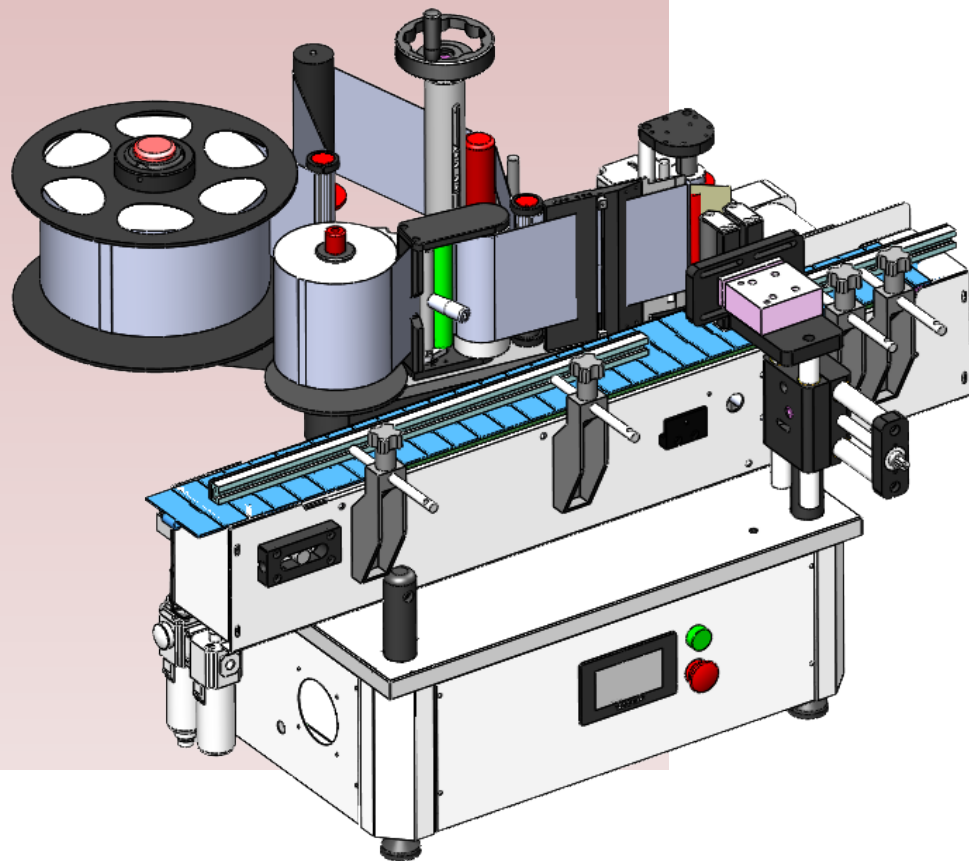

[WWW.SNEEDCODING.COM](http://WWW.SNEEDCODING.COM) | (833) 926-3464 | [SUPPORT@SNEEDCODING.COM](mailto:SUPPORT@SNEEDCODING.COM)

Hey there,

Congrats on scoring your very own “SNEED-PACK label applicator!” We’re stoked that you’re now a part of our automation tribe. This manual is like your compass to navigate through all your new gear’s cool features and hacks. Feeling like a deep dive? Swing by and schedule a video chat with our tech pros - just zap that QR code. Or if it’s a quick fix you need, the other QR code will whisk you away to our online Help Desk faster than you can say, “Automate everything!” Thanks for choosing Sneed Coding - get ready to rock the world of automation with us!

**Schedule a meeting with one of our technical service pros:**



**Visit our Help Desk:**



## Contents

Safety Precautions .....	3
Parameters.....	4
Diagrams .....	5
The Applicator Assembly.....	5
Label Threading.....	6
The Label Gap Sensor .....	6
Teaching the sensor .....	7
Set-up.....	8
Air Supply .....	8
The Bottle Separator .....	8
The Bottle Clamp.....	9
Instructions.....	10
The Bottle Sensor.....	11
Setting Teach Mode .....	12
Setting The Sensing Threshold.....	12
Operating the User Interface.....	13
The main menu.....	13
Function Selection Menu.....	14
Manual Debugging Menu .....	14
I/O Monitor.....	15
Parameters.....	15

## Safety Precautions



- ✿ Keep your hands clear of any moving parts while the equipment is in operation, and always power down prior to inspection. Failure to do so may cause bodily harm.



- ✿ Risk of electric shock, make sure the machine is properly grounded before use.



- ✿ Do not alter the mechanical or electrical systems. Any changes could result in malfunction or injury.

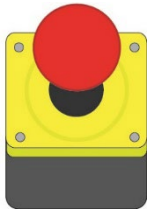

- ✿ Always turn off the power to the equipment before replacing any consumables.

## Parameters

Labeling accuracy	≤ 1mm
Labeling speed	30-50 labels per/min
Equipment footprint	2200 x 1200 x 1700mm (L x W x H)
Power Supply	220V 50/60Hz
Weight	215Kg

## Diagrams

### The Applicator Assembly

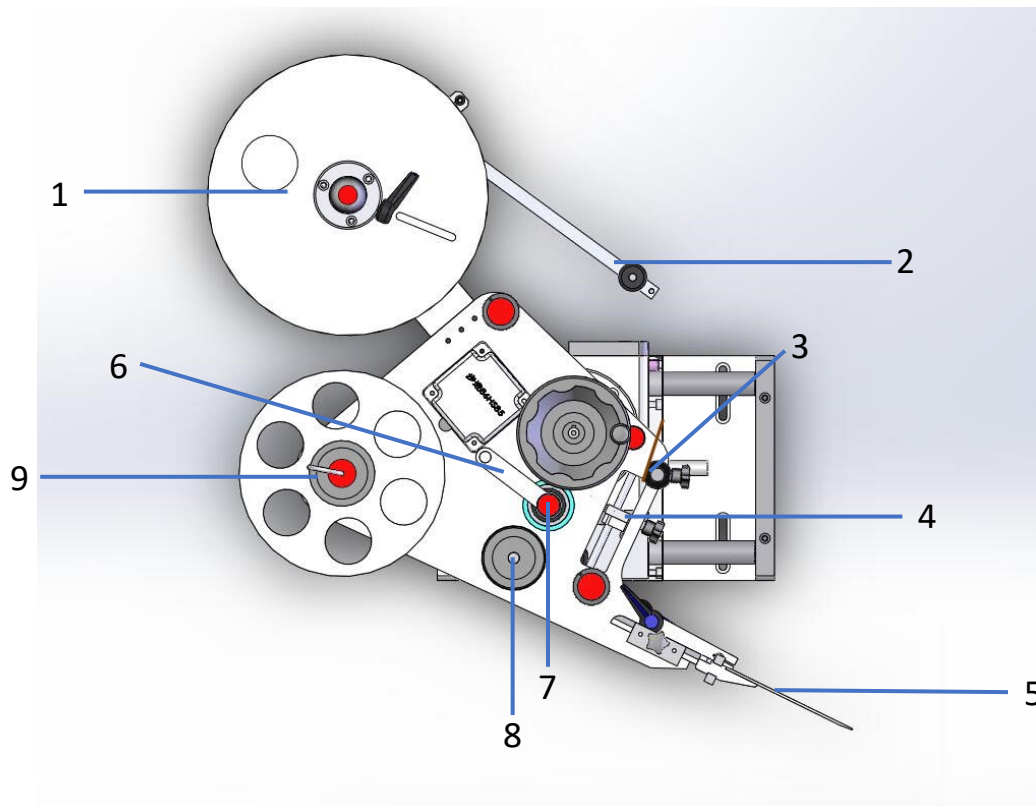

1. **Label tray:** Utilized to install the label roll (ensure the label tray is securely fastened when affixing labels)
2. **Tension lever/arm:** Employed for halting the label, preventing its loosening, and sustaining label tension (tension testing: Following label spinning, manually initiate the traction motor to move the label. As the swing rod descends, the label disc will autonomously rotate, indicating proper tension).
3. **Pressure plate:** Ensures the labels are pressed against the roller leading into the sensor tunnel.
4. **Gap label sensor:** Sends the trigger to the PLC, telling the friction puller to stop pulling the labels.
5. **Separator plate:** Separates the label from its backing.
6. **Cam handle:** Engage or dis-engage the belt-driven friction cam
7. **Driven friction roller:** pulls the label in conjunction with the secondary friction roller.
8. **Secondary friction roller**
9. **Label winder:** Winds the label backing.

## Label Threading

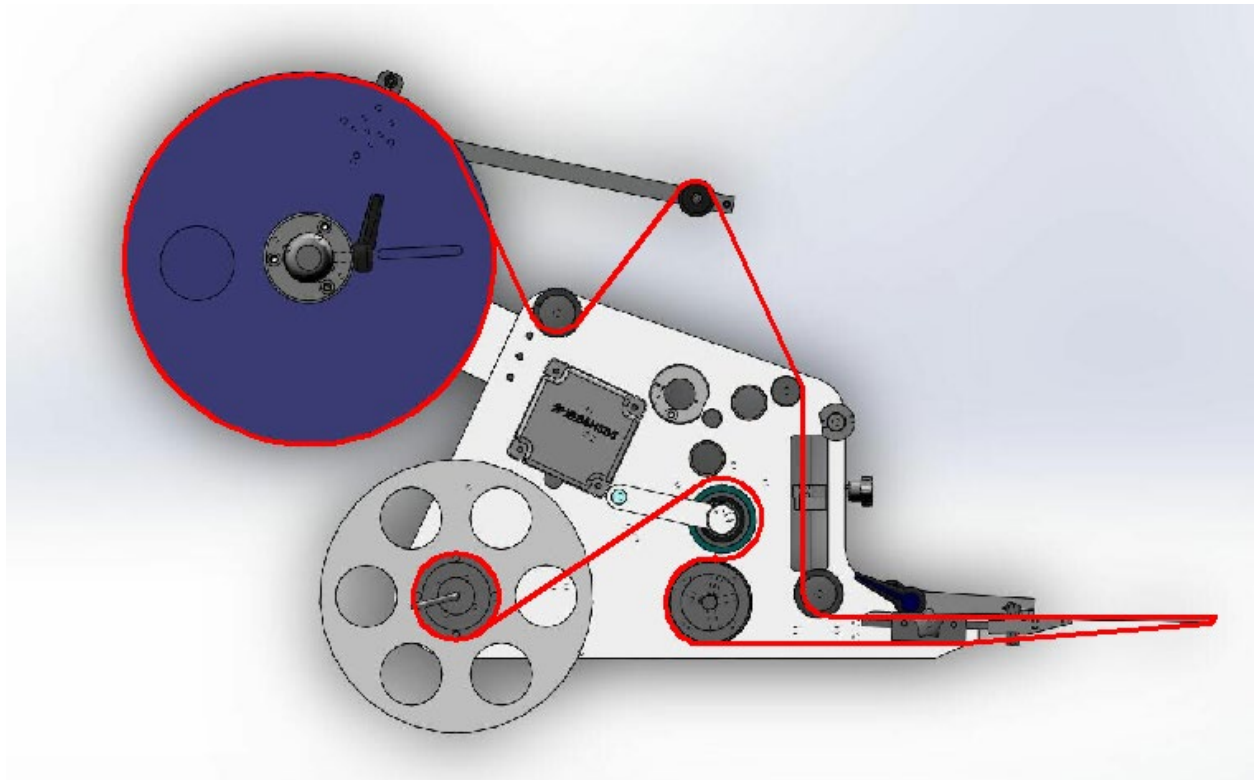

The diagram indicates the correct path for threading the labels.

## The Label Gap Sensor

The label applicator is equipped with an NPN style gap label sensor. It is used to set the labels stop timer.

**Stop timer** – controls the duration of the friction roller / label pull.



## Teaching the sensor

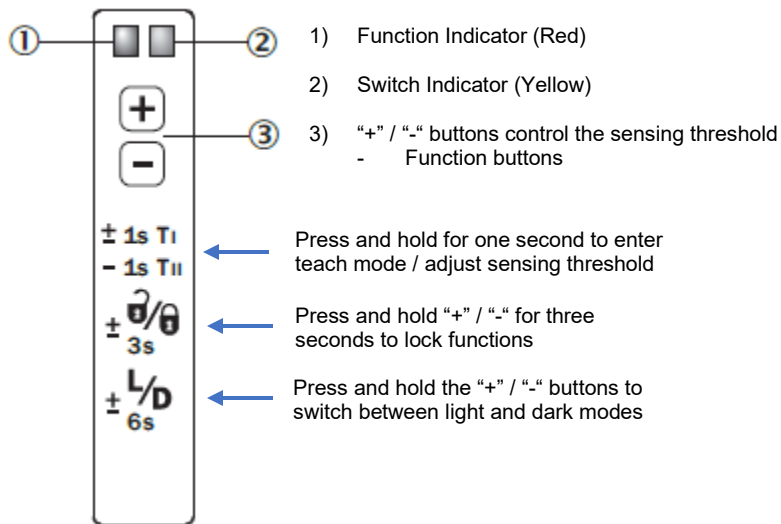

### Instructions

1. Position the label inside the sensing forks, then press and hold the "+" / "-" buttons for one second and release. The red function light will begin blinking.
2. Remove the label, and with the baking paper in the forks, press the "-" button one time. The yellow switching light should turn on, indicating a successful teaching.

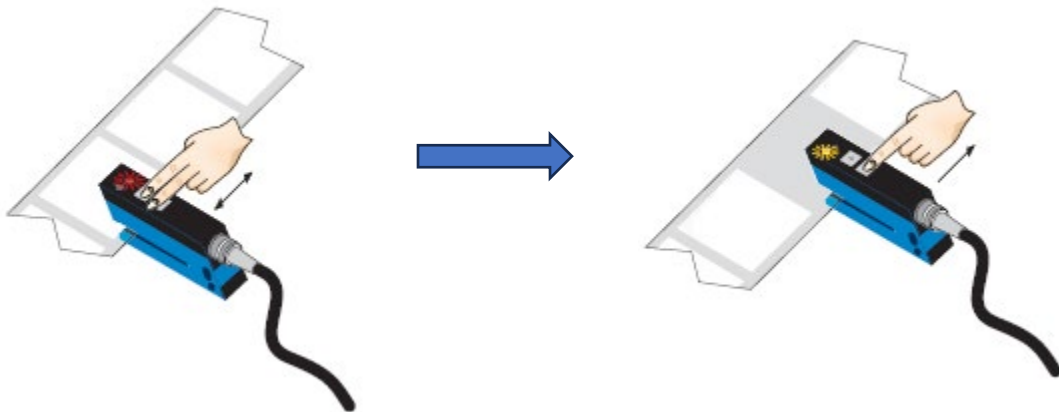



## Set-up

### Air Supply

Begin by connecting the air supply. The normal operating pressures are between 50 – 60psi.

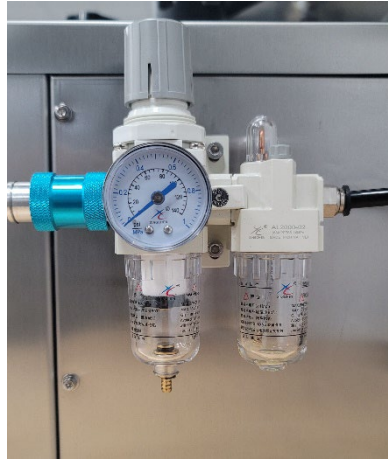

### The Bottle Separator

1. Begin by adjusting the guide rails to suit your bottle.
2. The green separator wheel should be set just slightly further in than the guide rails to stop the bottle.
  - Loosen the 4 screws holding the electric motor in place to adjust the position of the bottle separating wheel.

The Speed at which the separating wheel turns can be adjusted with the knob on the back of the machine.



## The Bottle Clamp

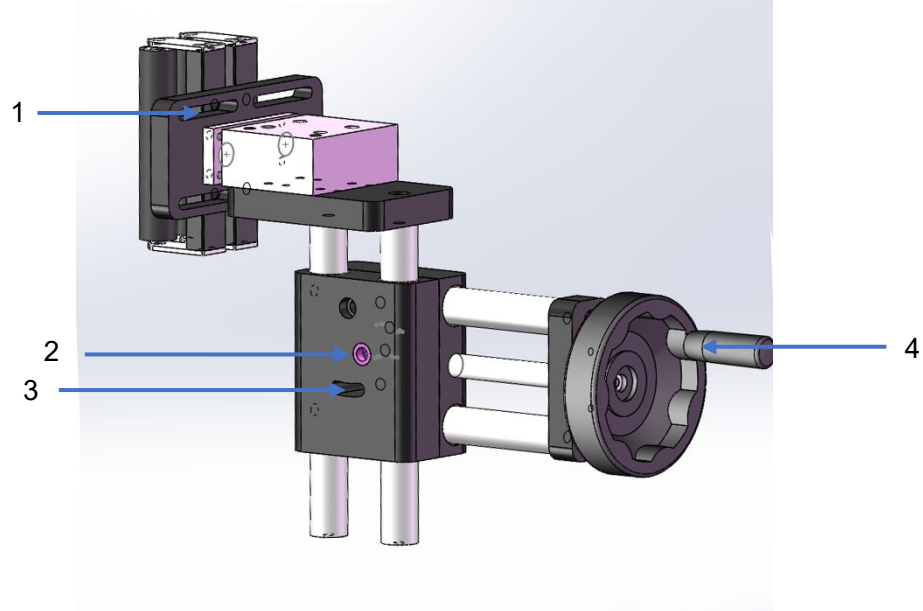

1. Screws set the roller width.
2. Loosen to Raise or lower the mechanism.
3. Loosen to set the mechanism angle.
4. Withdrawal or advance the rollers towards the label applicator. (see the image below)

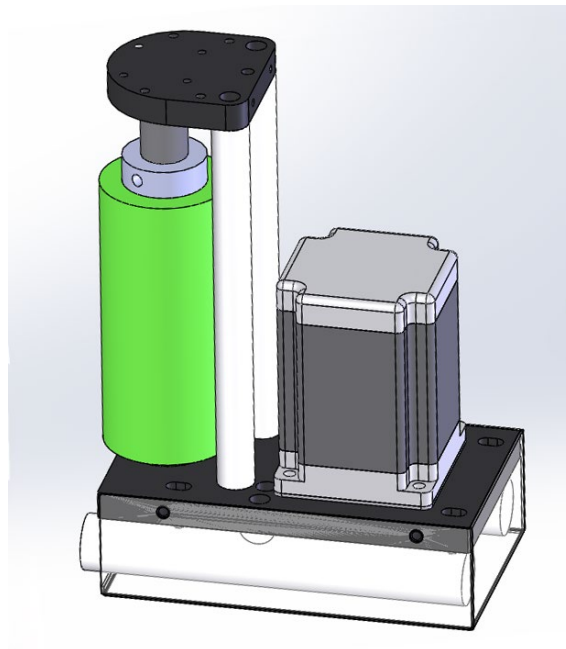

## Instructions

1. Begin by manually extending the rollers. Navigate into the “Manual Debugging” menu to activate the individual components.

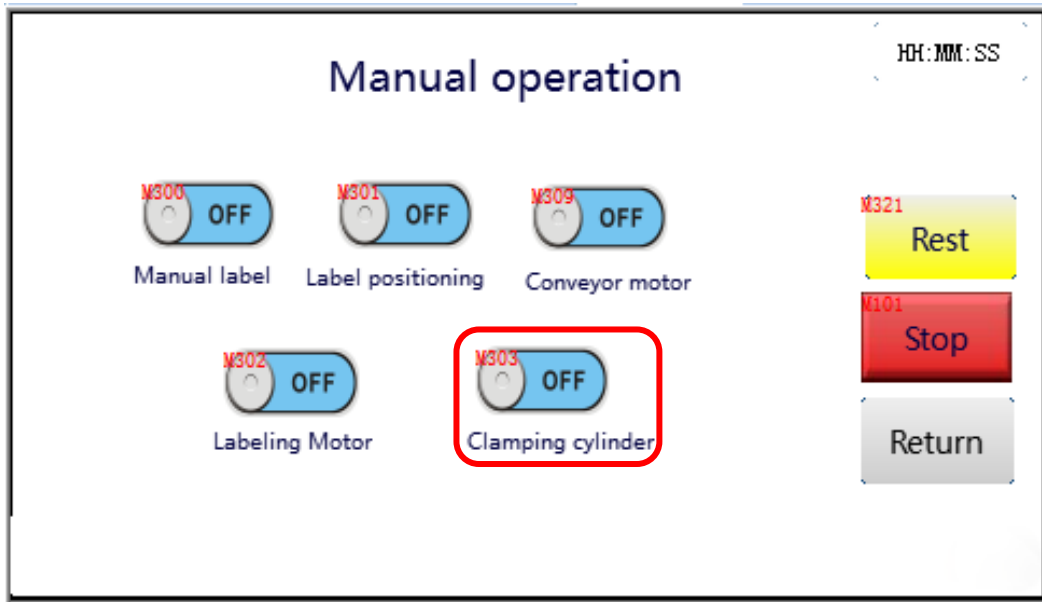

2. With the clamp extended, set the width, height, and angle of the rollers so that the bottle is firmly positioned between all three rollers.



## The Bottle Sensor

The label applicator has a digital fiber sensor to detect bottles and trigger the label application.

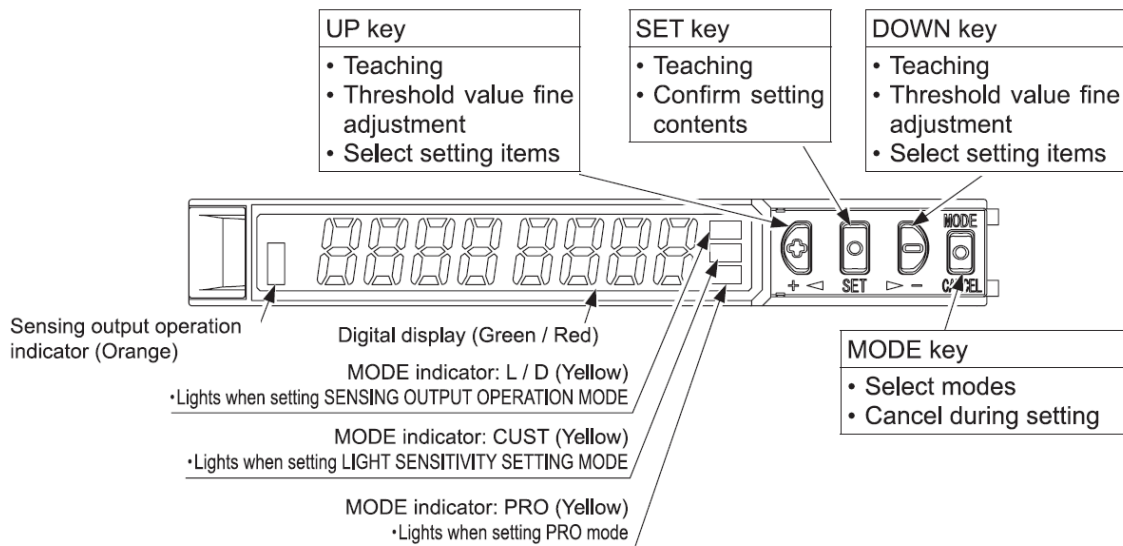
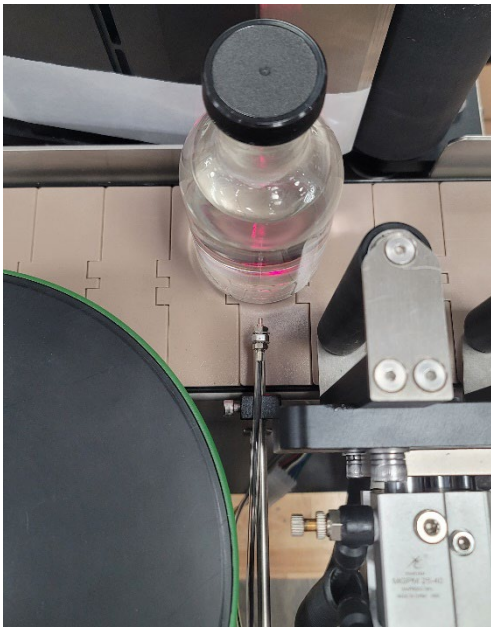

## Setting Teach Mode

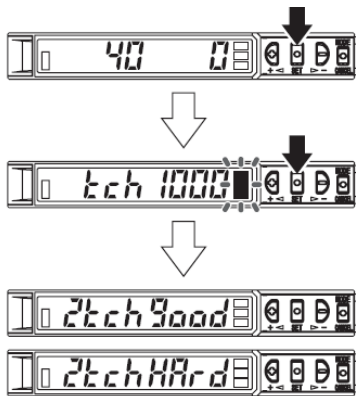

1. With the bottle PRESENT, press the SET key.
2. With the bottle ABSENT, press the SET key.
3. Indicates that stable sensing HAS been achieved.
4. Indicates that stable sensing HAS NOT been achieved.

If multiple attempts to teach the sensor have not been successful, the sensing threshold can be set manually.

## Setting The Sensing Threshold

To set the sensing threshold, use the arrow keys to increase or decrease the value. Once you have achieved consistent stable sensing, press the set key to confirm the setting.

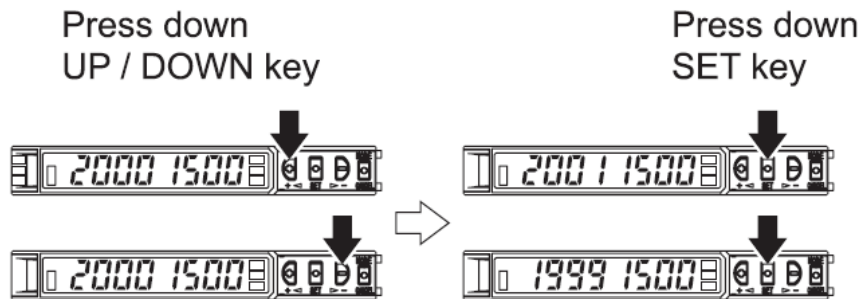

# Operating the User Interface

## The main menu

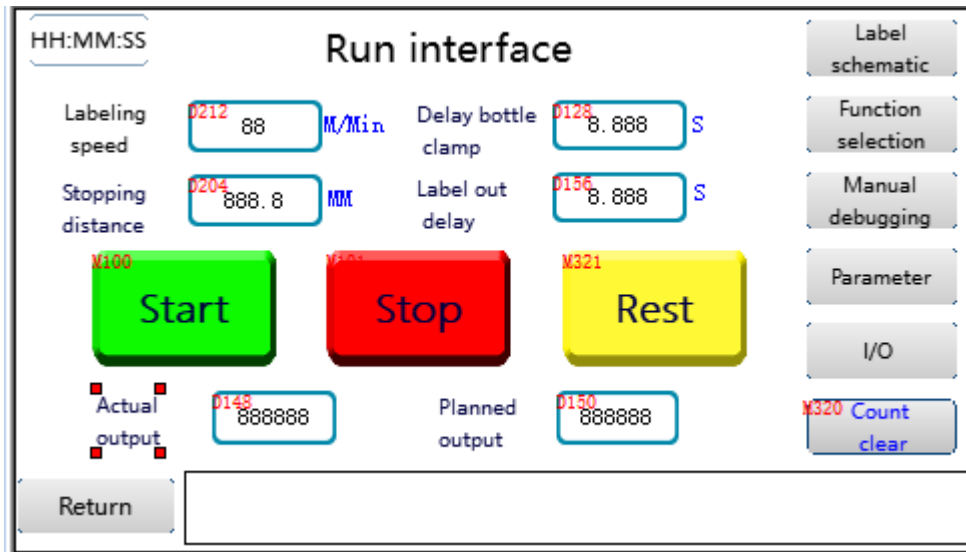

1. Labeling Speed – The speed at which the friction roller is pulling the label roll.
2. Delay Bottle Clamping – The amount of time after the bottle sensor is triggered before the clamping mechanism is engaged.
3. Stopping distance - set the interval to pull time per label.
4. Label Out Delay – The amount of time the bottle clamping mechanism is engaged.
  - Set the “planned output” to stop labeling at a pre-determined value. The actual output is the current label count.

- Label schematic - Shows an image of the correct label path.
- Function selection - Allows the user to set the operational state of specific functions during use.
- Manual debugging - Manual engagement of all mechanical operations during periods of none use. (This feature will not work when the labeler is in standard operation)
- Parameter - Advanced user settings
- I/O - Monitoring screen.

## Function Selection Menu

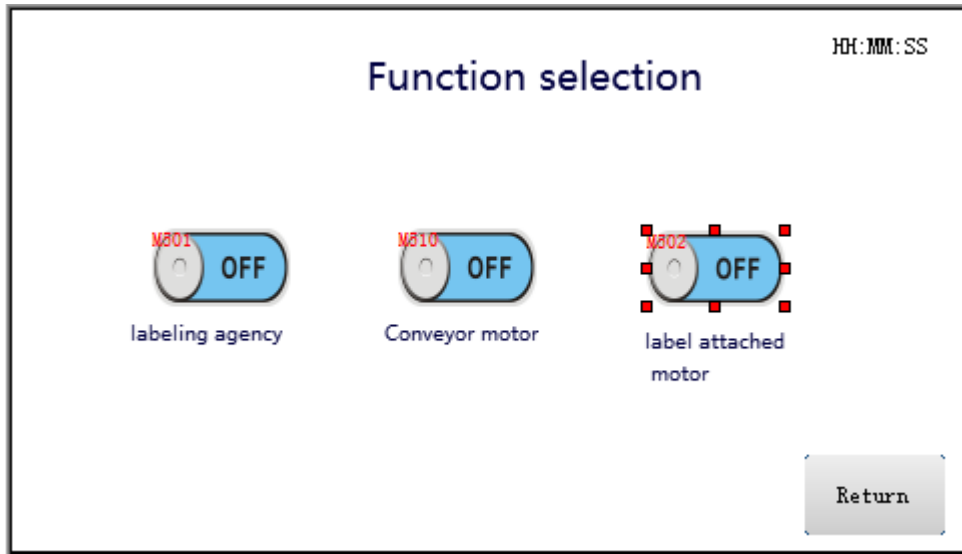

- The features in this menu will only function during normal operation
1. Labeling agency – disable the bottle sensor, this will let bottles through with being labeled.
  2. Conveyor motor – stop the conveyor.
  3. Label attached motor – set the roller responsible for turning the bottle to an on or off state.

## Manual Debugging Menu

The settings in this menu will only work when the labeler is set to “STOP.”

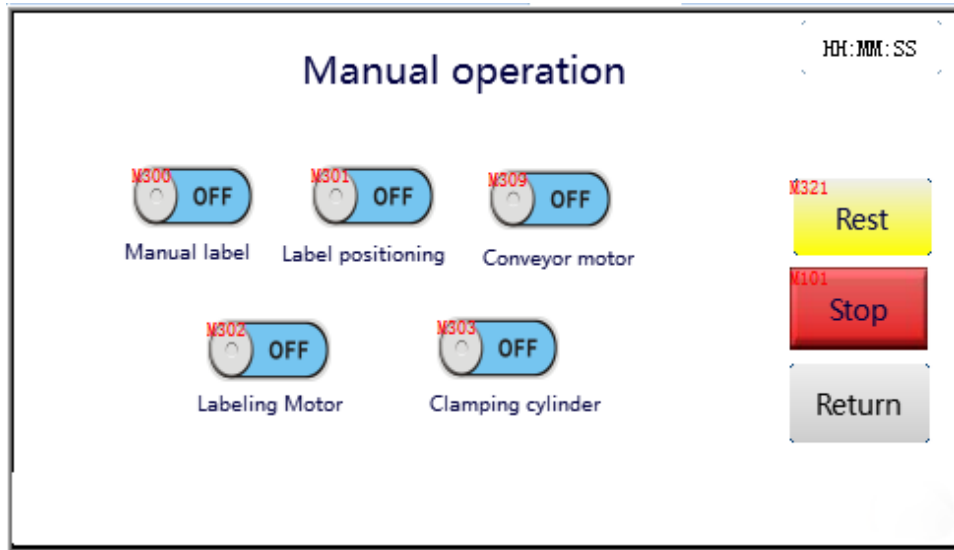

1. Manual Label – Manually spool the label roll by holding down the slider.
2. Label positioning – pull a single label. (The stop timer is applied).
3. Conveyor motor – activate or de-activate the conveyor motor.
4. Labeling motor – activates or de-activates the bottle roller.
5. Clamping cylinder – Engage the clamping mechanism.

### I/O Monitor

The I/O screen is used to monitor the operation of individual components. A green light indicates the sensor, motor, or clamp is activated.

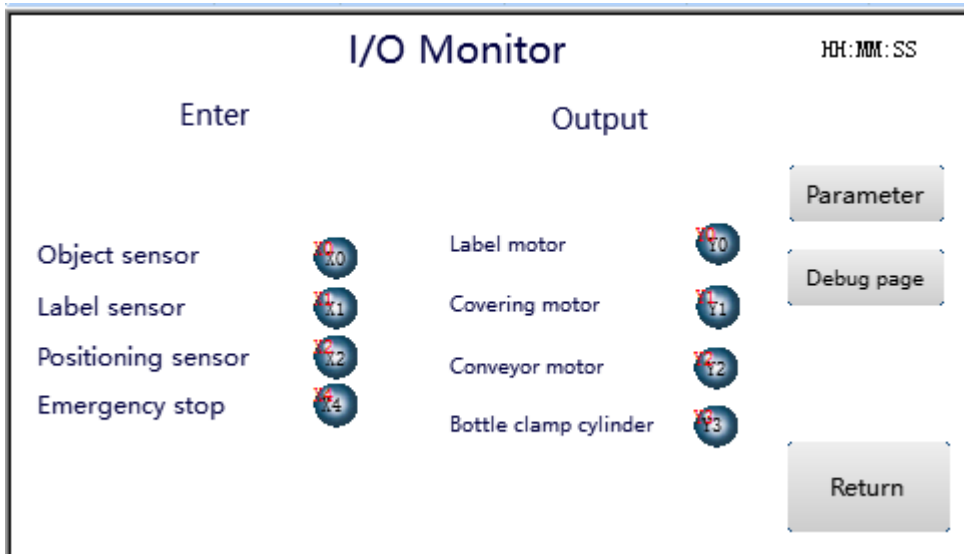

### Parameters

The Parameters menu is intended to allow advanced users to control detailed settings. To access the menu, use the **pass code: 2010**.

