

SNEED PACK CS-30XS



User Manual

To Schedule a Call:

<https://info.sneedcoding.com/meetings/richardturner/printer-introduction>



Sneed Coding Help Desk:

<https://help.sneedcoding.com/>



Thank you for your purchase of the SNEED-PACK CS-30XS side belt driven carton sealer. In this manual you will find the basic operating and maintenance procedures to ensure your success with the CS-30XS. Please read the manual carefully before operating the equipment.

Safety Precautions



- Keep hands clear of any moving parts while the case sealer is in operation and always power down prior to inspection. Failure to do so may cause bodily harm.



- Risk of electric shock, make sure the machine is properly grounded before use.



- Do not alter the mechanical or electrical systems. Any changes could result in malfunction or injury.

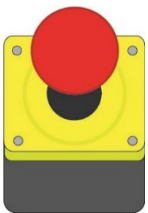

- Always turn off power to the case sealer when changing the tape roll or performing maintenance.

Contents

- Specifications 4
- Component Diagram 5
- Setting up the Case Sealer 6
 - Adjusting the deck height 6
 - Adjusting for your carton dimensions..... 7
 - Installing the tape 8
 - Adjusting the tape position..... 9
 - Setting the tape tension..... 9
- Troubleshooting..... 10
 - Circuit Diagram 10
- Exploded Views 11
 - Main body 11
 - Parts list..... 11
 - Lifting platform 12
 - Parts list..... 13
 - Upper tape head mounting rack..... 13
 - Parts list..... 14
 - Drive Belts 14
 - Lower drive belt assembly 14
 - Upper drive belt assembly 15
- Tape Head 17
 - Tape head exploded view 18
 - Swing arm / Tape applicator 20
 - Parts list..... 20
 - Cutting head..... 22
 - Tape arm 24
 - Parts list..... 24

Specifications

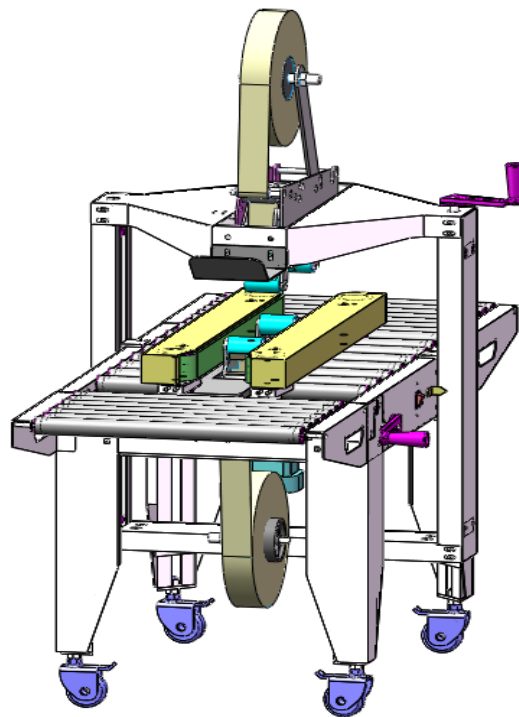

- ✿ **width:** 8cm~30cm
- ✿ **height:** 8cm~30cm
- ✿ **length:** 13cm~+∞mm
- ✿ **Deck height:** 60cm~75cm
- ✿ **Overall dimensions:** L71cm ×W53.5cm ×H150cm (excluding front and rear roller racks)
- ✿ **speed:** about 20 cartons/min (the length of carton is less than 55cm)
- ✿ **Applicable power source:** 220v/380v @ 50HZ
- ✿ **Applicable tape:** 48mm
- ✿ **Weight:** 200lbs

Component Diagram

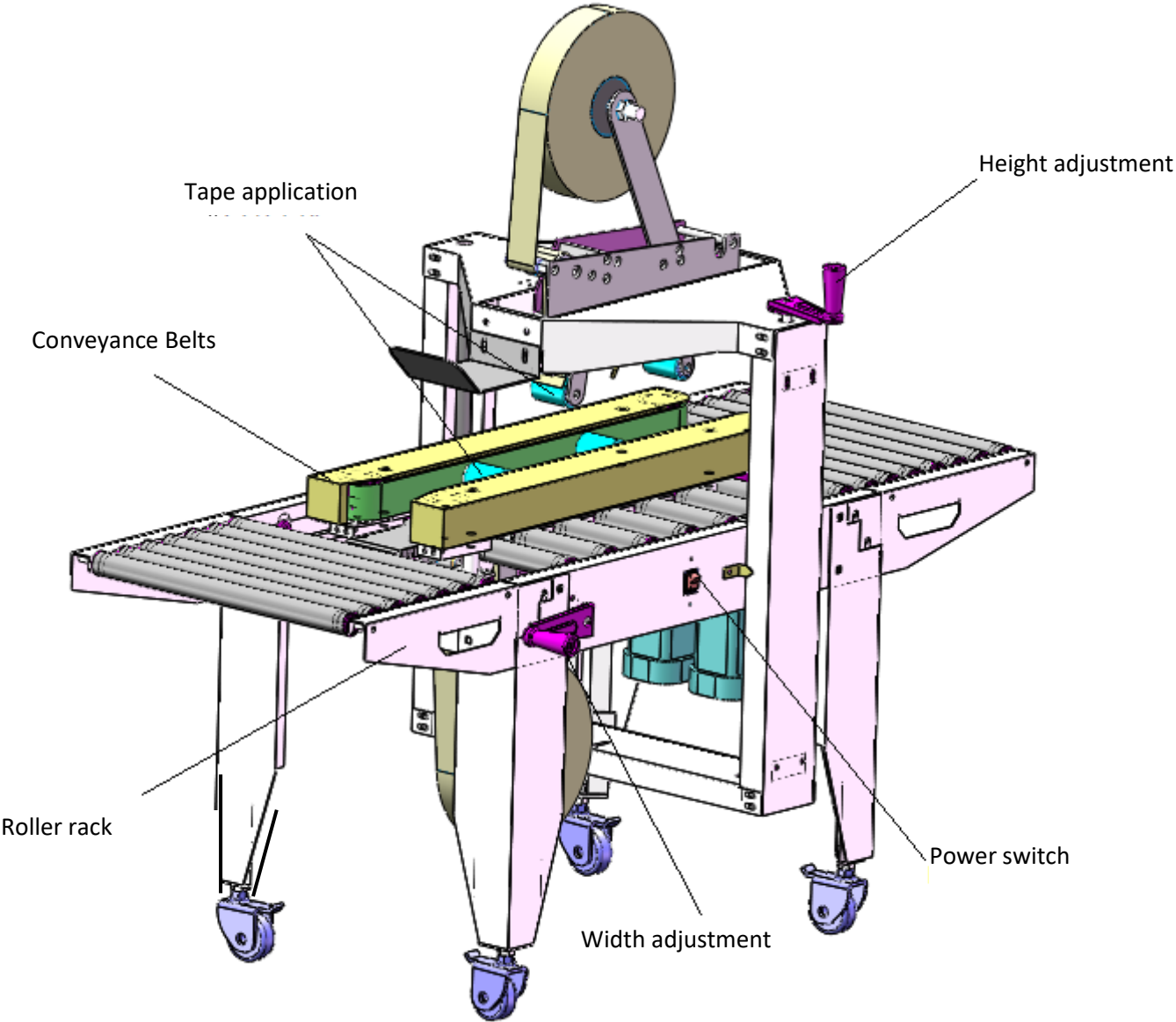

Figure 1

Setting up the Case Sealer

Adjusting the deck height

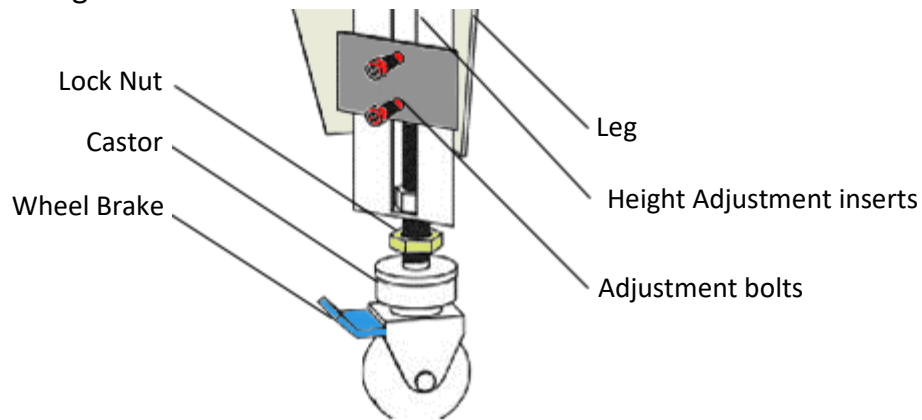

Figure 2

1. Begin by lifting the case sealer to the desired height with a pallet fork, dolly, or jack and secure it safely in place.
2. Loosen the “adjustment bolts” on each leg and allow the “Height adjustment Insert” to drop the floor.
3. Tighten the adjustment bolts and repeat these steps for each leg.
4. Once you have tightened all of the legs remove the lifting device holding the case sealer in place.
 - ❖ Always consider safety and never lay down underneath the case sealer while adjusting the legs.

Adjusting for your carton dimensions.

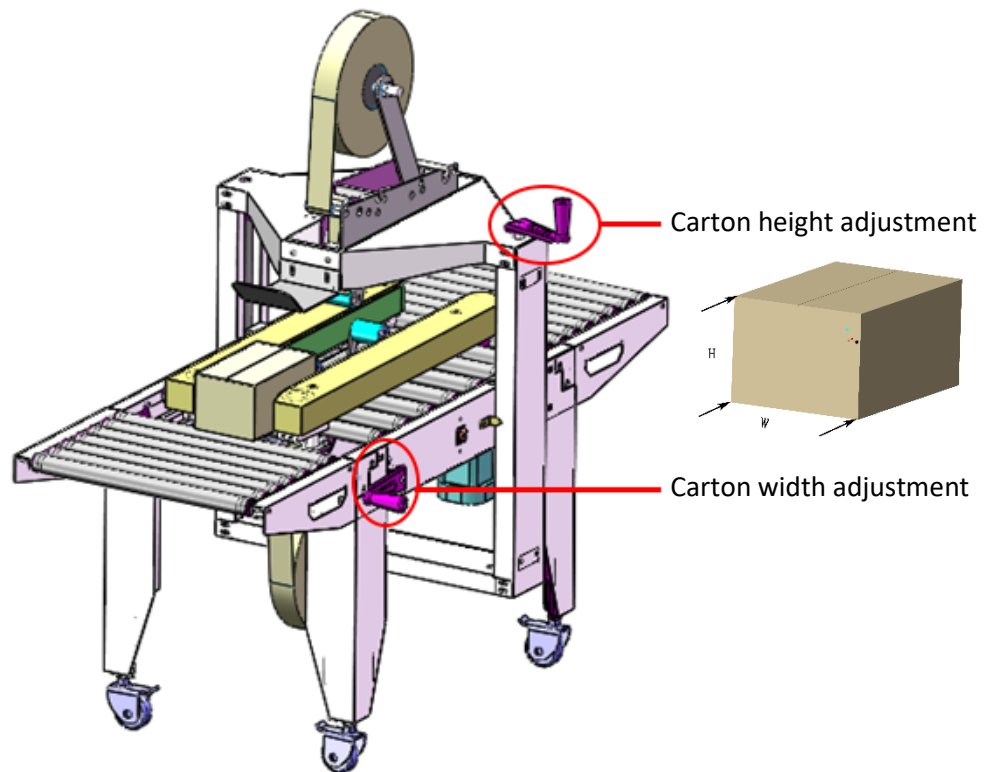
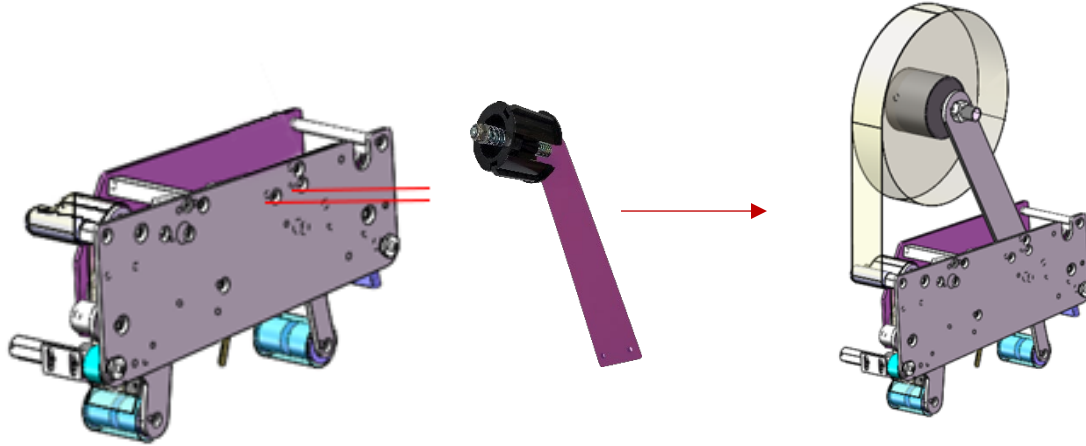

Figure 3

1. To set the case sealer to fit the dimensions of your carton/case use the adjustments shown in Figure 3.
2. The adjustment handles will be installed backwards for shipping, remove them using the included 10mm wrench and reinstall.

Installing the tape

1. Begin by attaching the tape arms to each tape head using the included screws. (top and bottom)



2. Next Install the tape onto the tape wheel so that when you pull the tape down the adhesive side is facing outward.
3. Now guide the tape under the first guide roller, over the one-way roller, and through the clip just above the last guide roller. **The red line in figure 5 shows the tape path**

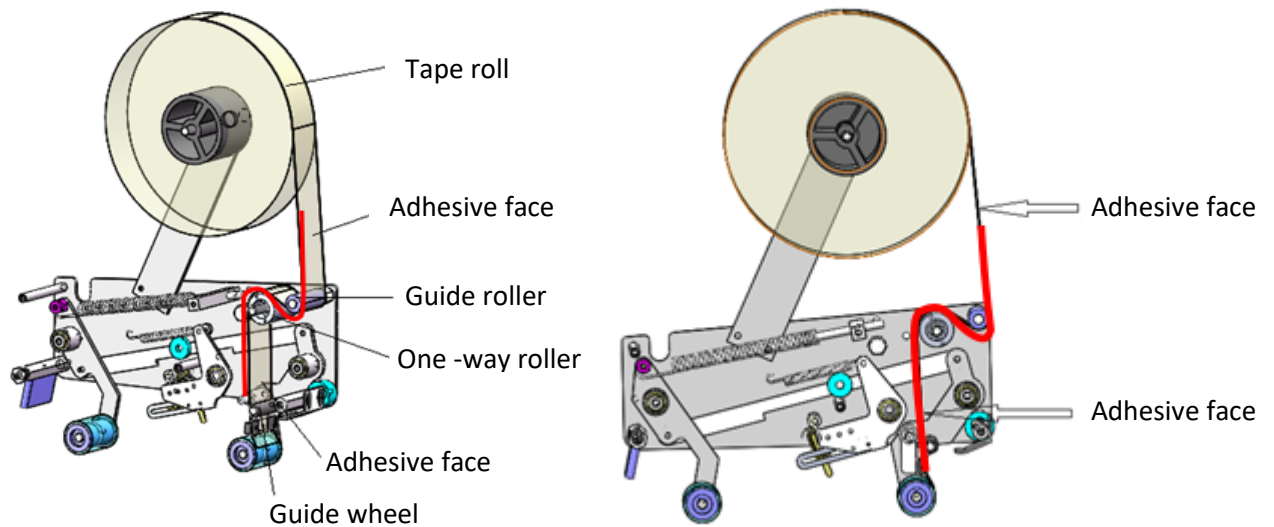

Figure 5

Adjusting the tape position

If you find that your tape is not lining up with the center of the box seems you can use the M18 nut shown in figure 6 to reposition the tape.

1. Remove the tape roll
2. Loosen the nut
3. Thread the tape spindle in or out to move the tape to the left or right on the arm.
4. Tighten the M18 nut into place when you have set the desired position

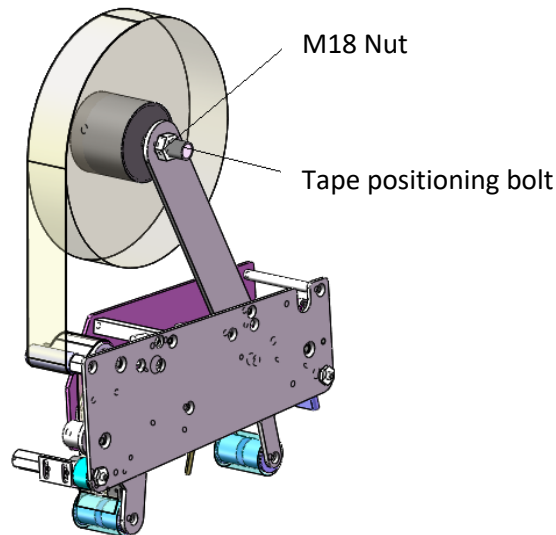
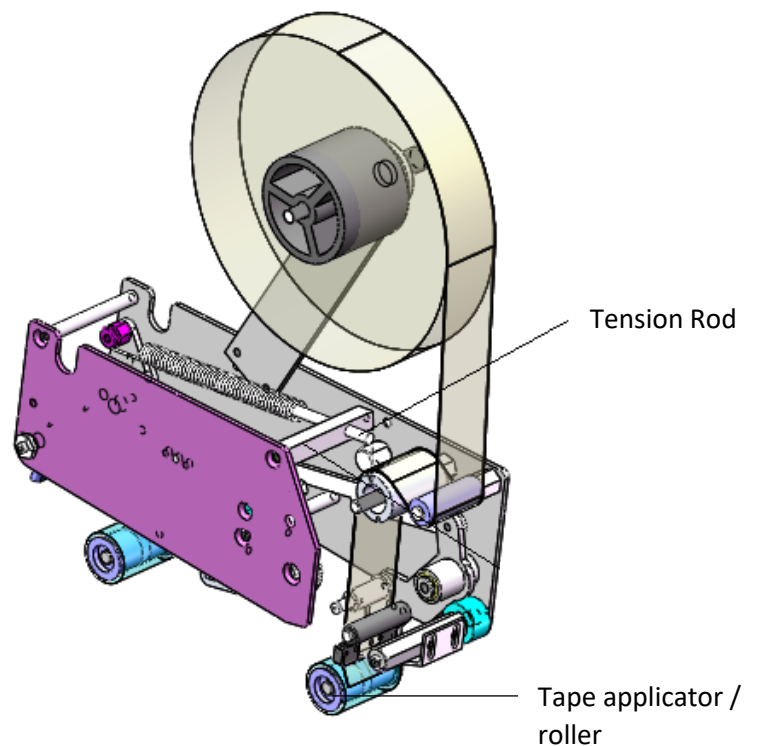

Figure 6

Setting the tape tension

- ❖ The tape applicators will come to you already adjusted. You may find that over time the tension needs to be adjusted.
- ❖ To loosen or tighten the tension of the tape applicators use the nut on the end of the tension rod
- ❖ Turn the nut right to tighten the spring and to the left to loosen



Troubleshooting

Issue	Cause	Solution
Tape does not cut	The tape head blade is no longer sharp Possible tape jam	1.Remove the tape jam. 2.Wipe clean any accumulated adhesive from the tape head with 90% isopropyl alcohol. 3.Replace the tape blade
The tape has been cut but only a section applied to the case/ carton	The Tape head is likely jammed	check to see if any parts of the tape head have come loose.
The tape has been cut but does not fit the seam	The main tension spring is too loose	Tighten the nut on the tension rod.
The carton gets stuck	The tension spring is too tight	Loosen the tension spring by backing out the nut on the tension rod
The tape is retracting or coming loose from the rollers		

Circuit Diagram (see Figure 8):

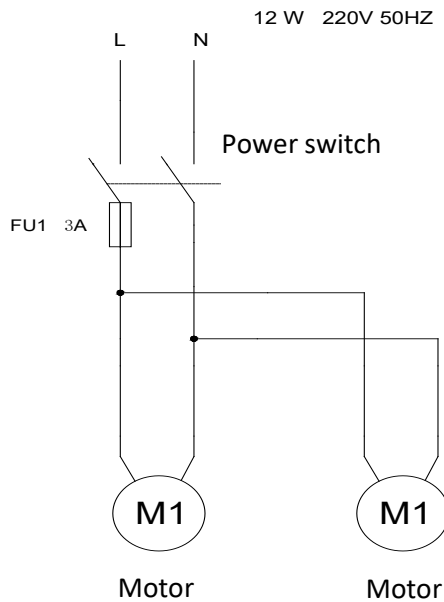
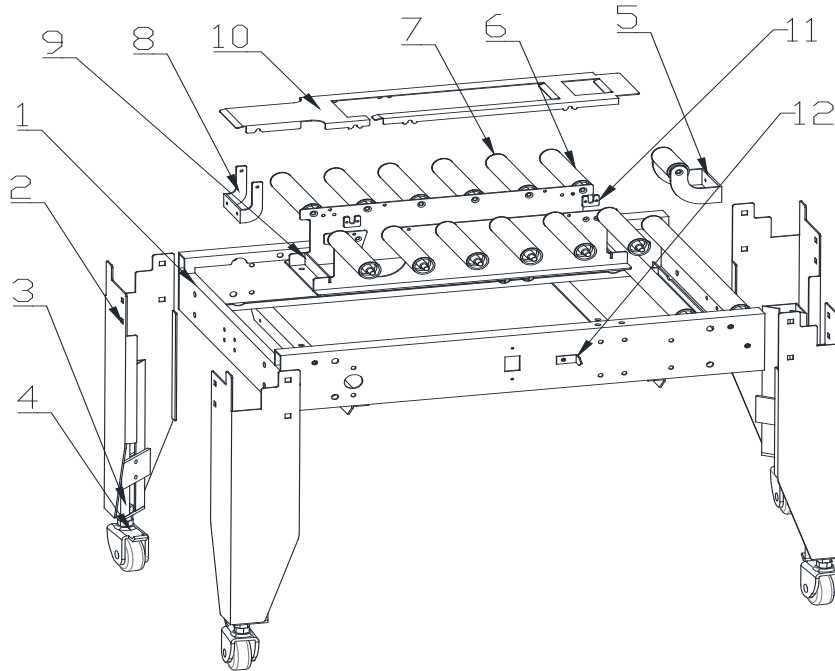

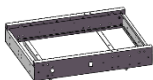





Figure 8







Exploded Views

Main body

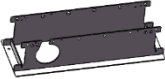

Parts list





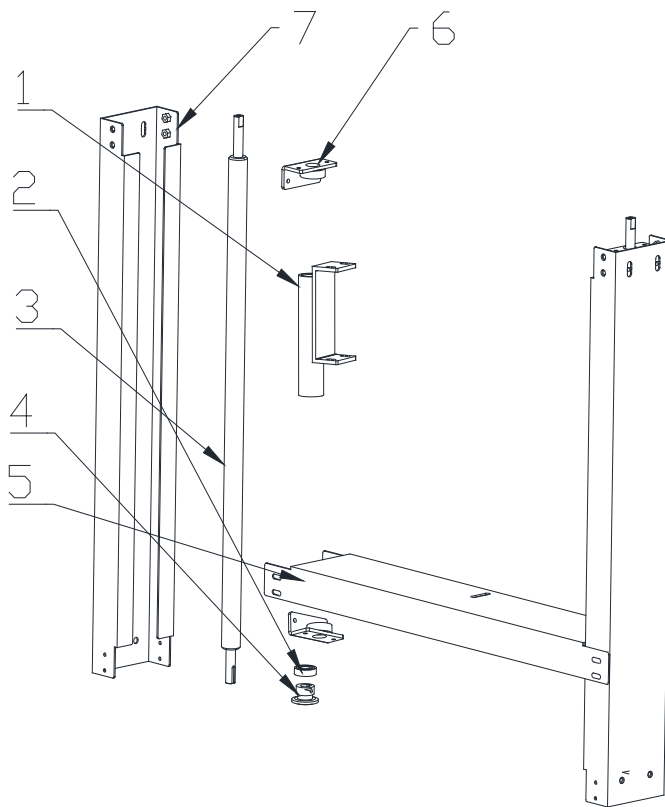

S/N	Part	Name	Quantity
1		Frame	1
2		Undercarriage	4
3		Adjusting undercarriage	4
4		Casters	1
5		Rear short roller rack	1
6		φ32*83 roller	12

7		Roller wheel	28
8		Small support plate	1
9		Lower cutter rack	1
10		Lower mandrel cover plate	1
11		Single U-shaped cleat	4
12		Pointer	1

Lifting platform





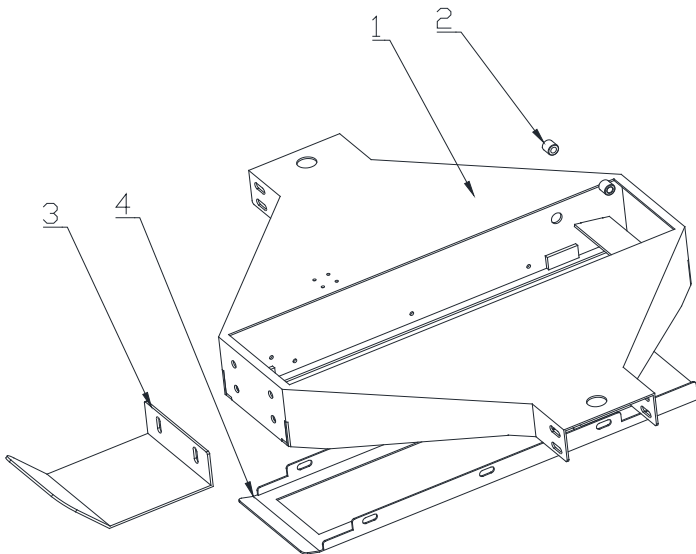

Parts list

#	Part	Name	Quantity
1		Lifting threaded tube	2
2		Bearing 6001	4
3		Lifting threaded axle	2
4		3/8-inch and 12-tooth chain wheel	2
5		Chain cover	1
6		Lifting bearing seat 1	2
7		Pillar	2

Upper tape head mounting rack

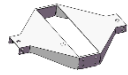

Parts list

#	Part	Name	Quantity
1		Upper mandrel mounting rack	1
2		Upper cutter rack mandrel fixed leg	2
3		Upper cutter rack front guide plate	1
4		Upper cutter rack lower blanking plate	1

Drive Belts



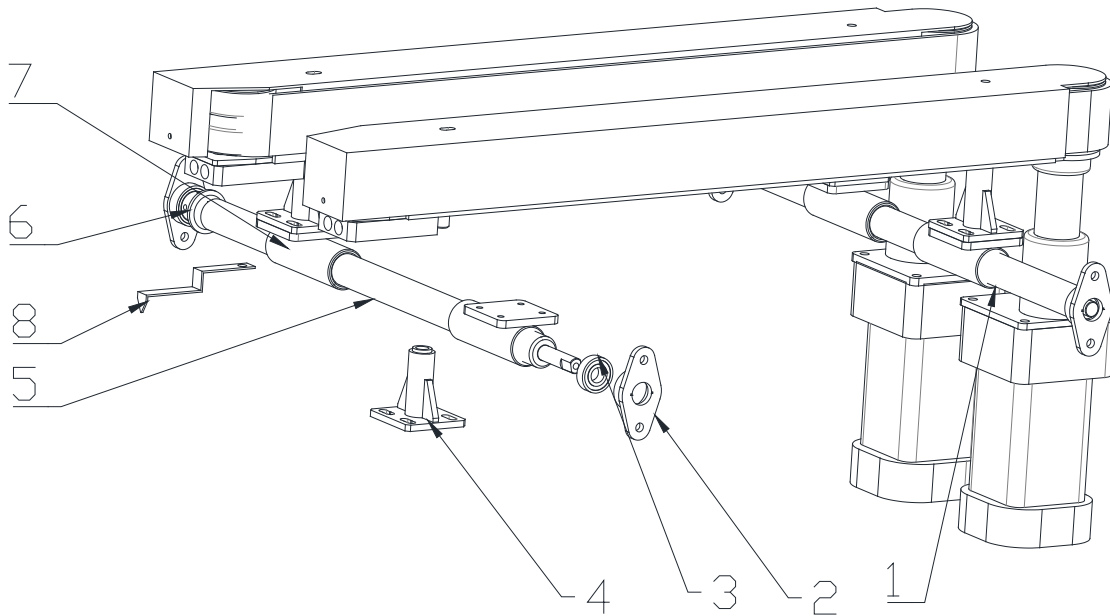

Lower drive belt assembly

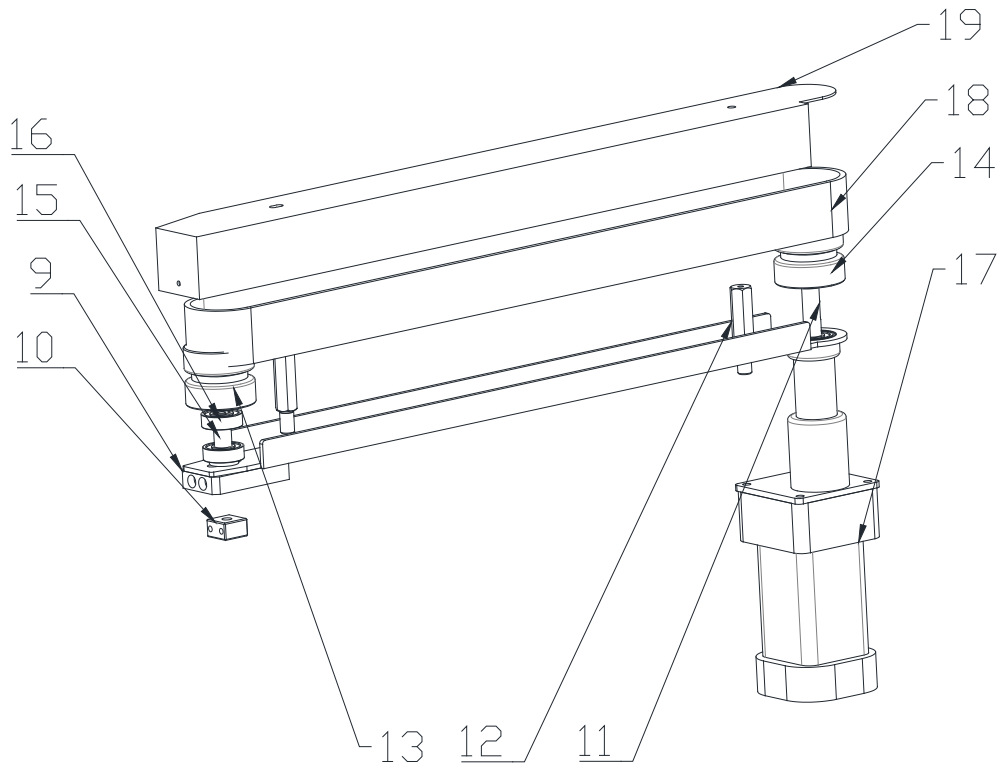













Upper drive belt assembly



Parts list

#	Part	Name	Quantity
1		Left and right threaded rods (rear)	1
2		Rhombus bearing seat	4
3		Bearing 6001	4
4		Belt supporting seat	4
5		Left and right threaded rods (front)	1
6		3/8-inch and 12-tooth chain wheel	2
7		Left and right threaded tube	4

8		Left and right adjusting pointers	1
9		Belt seat	1
10		Belt adjusting block	1
11		Driving shaft A	1
12		Belt cover support pillar	2
13		Driven wheel	1
14		Driving wheel	1
15		Driven shaft	1
16		Bearing 6202	4
17		VTV motor	1
18		Belt	1
19		Belt cover	1

Tape Head

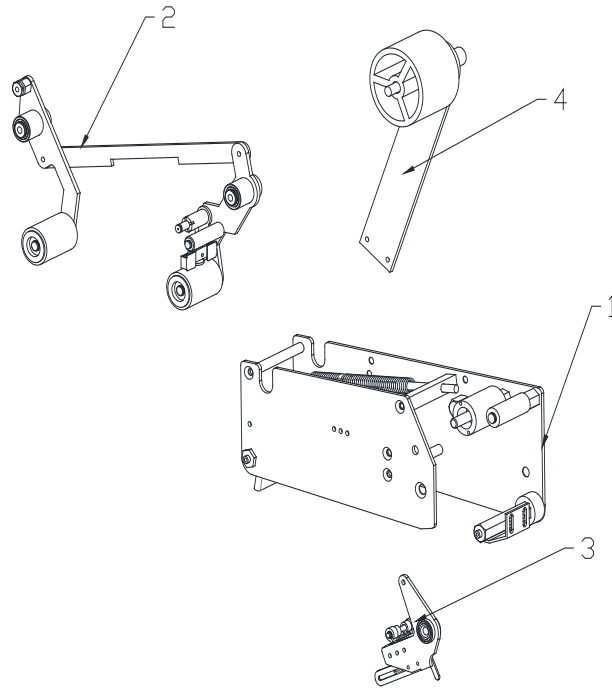





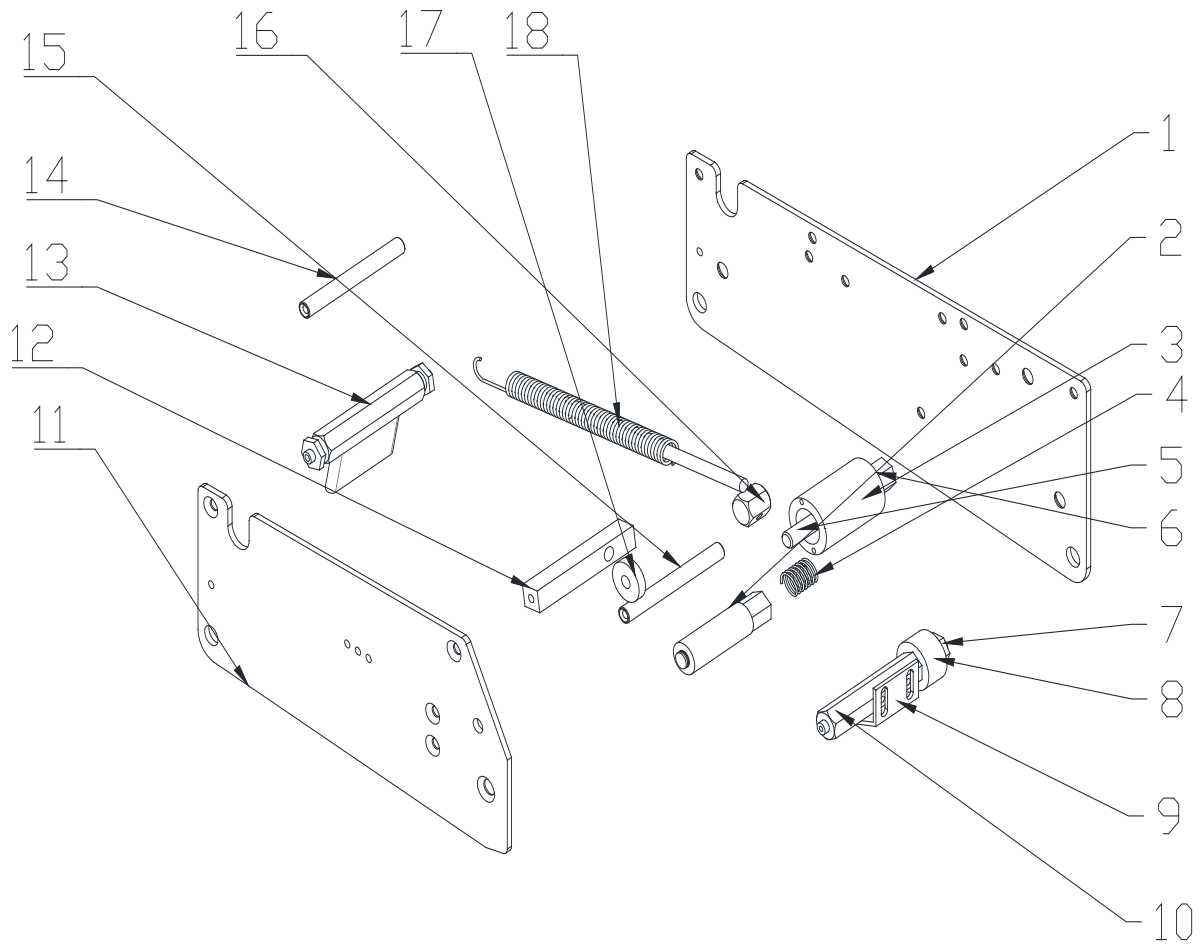

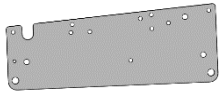

#	Name	Quantity
1	Tape head frame	1
2	swing arm	1
3	Cutter	1
4	Tape holder	1

Tape head exploded view



Parts list

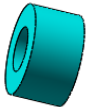
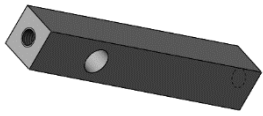



#	Part	Name	Quantity
1		Left panel (large) of mandrel	1
2		PE guide wheel set of mandrel	1
3		One-way small knurl wheel of mandrel	1

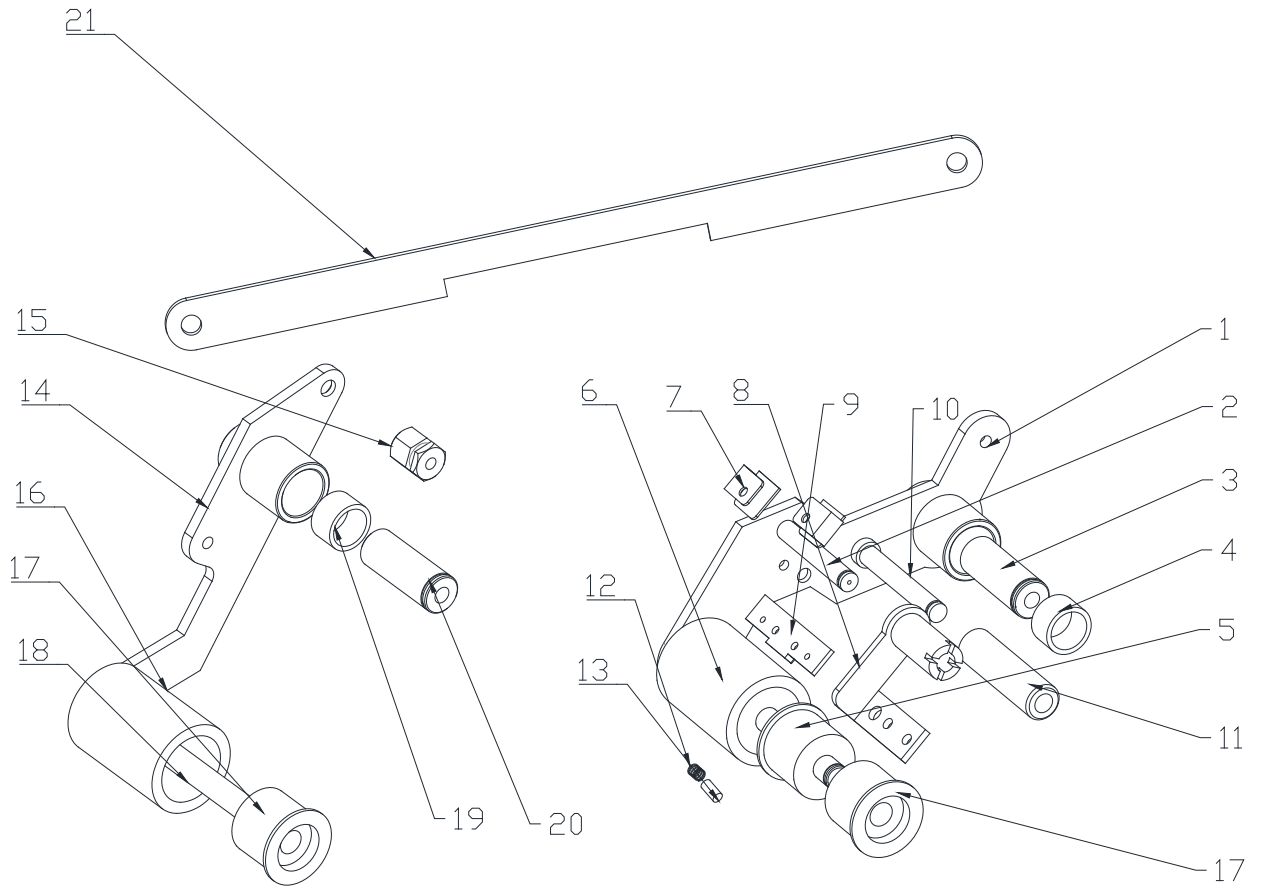



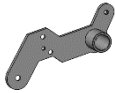

4		One-way wheel pressure spring	1
5		One-way small knurl wheel axle of mandrel	1
6		One-way bearing HF1616 of mandrel	1
7		Hexagonal threaded axle of mandrel	1
8		Mandrel catch wheel	1
9		Mandrel front guide plate	1
10		Front pivot axle of mandrel	1
11		Right panel of mandrel	1
12		Square locking axle of main tension spring of mandrel	1
13		Mandrel brush set	1
14		Mandrel panel locked axle	1
15		Mandrel panel locked axle	1
16		Adjusting hexagon prism T2-24 of mandrel tape sticker wheel	1
17		Mandrel catch wheel	1
18		Mandrel tension spring	1

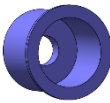
Swing arm / Tape applicator

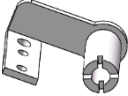

Parts list

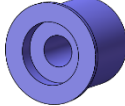
#	Part	Name	Quantity
1		Mandrel front swing arm assembly welding	1
2		Central spindle of mandrel tape sticker wheel	1
3		Forward and backward swing fixed axle of mandrel	1
4		Forward and backward swing cutter copper bush of mandrel	2
5		Pored chock plug	1





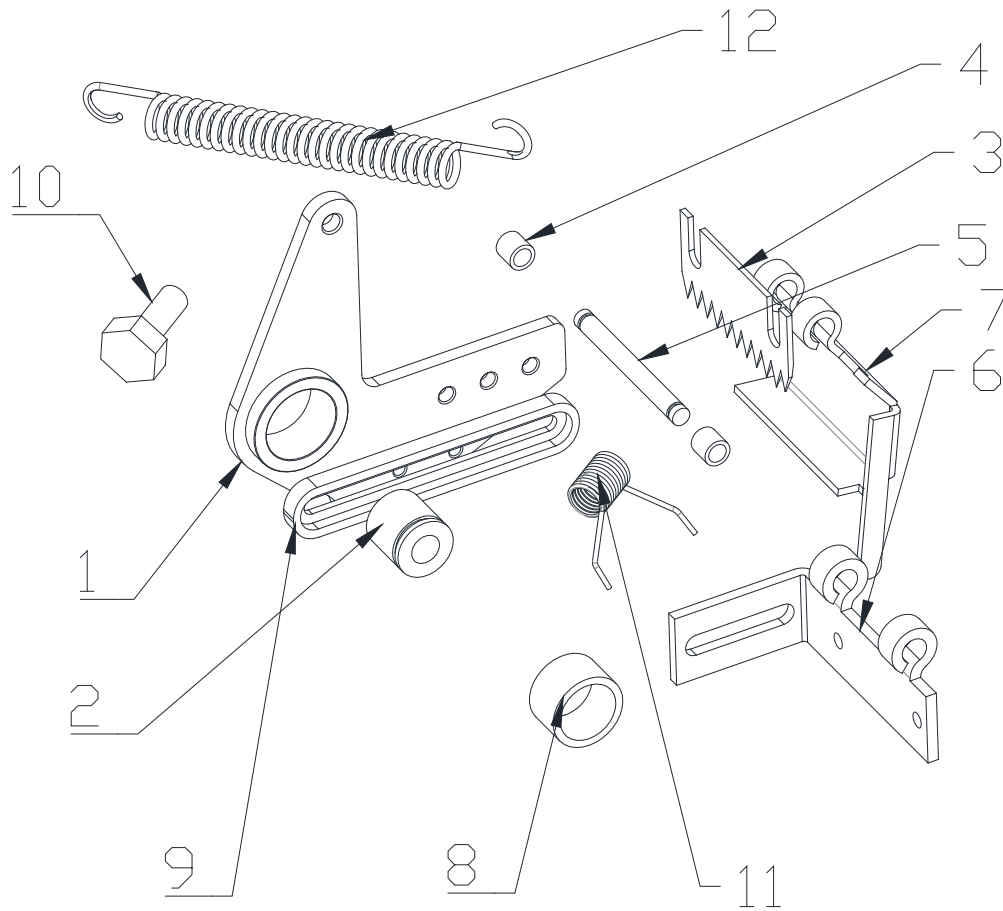

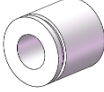
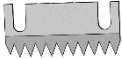

6		Front rubber wheel 2-cun	1
7		Mandrel cleat	2
8		2-cun tape support rack assembly weldment of mandrel	1
9		Mandrel tape top plate	1
10		Mandrel knurling guide wheel axle	1
11		Mandrel knurl guide wheel	1
12		Pressure spring	1
13		Copper rod	1
14		Mandrel rear swing arm assembly welding	1
15		Locking hexagonal axle of mandrel main tension spring	1
16		Rear rubber wheel 2-cun	1
17		Non-porous chock plug	3
18		Central spindle of mandrel tape sticker wheel	1
19		Forward and backward swing cutter copper bush of mandrel	2
20		Forward and backward swing fixed axle of mandrel	1
21		Mandrel connecting rod	1

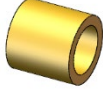
Cutting head

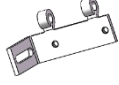

Parts list



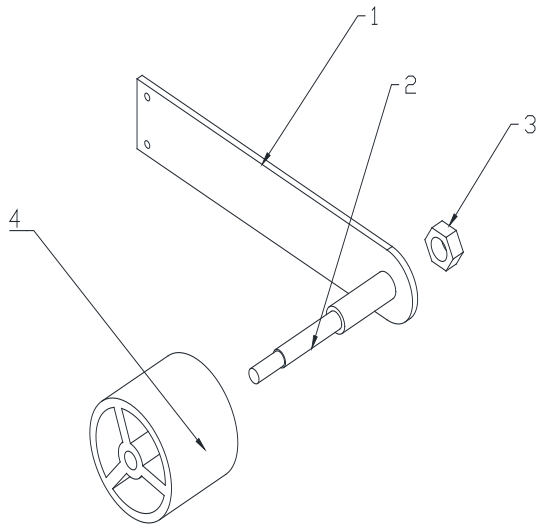

#	Part	Name	Quantity
1		Mandrel cutter seat	1
2		Cutter seat fixed axle	1
3		2-cun old blade	1

4		Cutter cover copper bush	2
5		Cutter cover central spindle	1
6		Cutter rack	1
7		2-cun cutter cover	1
8		Forward and backward swing cutter copper bush	1
9			1
10		M6 screws	2
11		Cutter cover torsion spring	1
12		Cutter tension spring	1

Tape arm

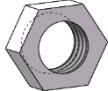

Parts list

#	Part	Name	Quantity
1		Tape holder support chip	1
2		Tape holder fixed axle	1
3		Tape holder fixed nut	1
4		Tape holder (round) and tensioning block	1