

best by: **SNEED**
Coding Solutions, Inc.

SNEED PACK CS-50SB USER GUIDE



To Schedule a Call:

<https://info.sneedcoding.com/meetings/richardturner/printer-introduction>



Sneed Coding Help Desk:

<https://help.sneedcoding.com/>



Thank you for your purchase of the SNEED-PACK CS-50SB side belt driven carton sealer. In this manual you will find the basic operating and maintenance procedures to ensure your success with the CS-50SB. Please read the manual carefully before operating the equipment.

Safety Precautions



- Keep hands clear of any moving parts while the case sealer is in operation and always power down prior to inspection. Failure to do so may cause bodily harm.



- Risk of electric shock, make sure the machine is properly grounded before use.



- Do not alter the mechanical or electrical systems. Any changes could result in malfunction or injury.

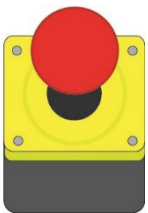

- Always turn off power to the case sealer when changing the tape roll or performing maintenance.

Contents

Specifications	4
Component Diagram.....	5
Setting up the Case Sealer	6
Adjusting the Deck Height	6
Installing the Roller Tables.....	7
Adjusting for your Carton Dimensions.....	8
Installing the Tape.....	9
Adjusting the Tape Position	10
Setting the Tape Tension	10
Common Issues	11
Circuit Diagram	12
Exploded Parts Diagrams	13
Main Body	13
Lift Mechanism.....	13
Parts List.....	14
Drive / Conveyance System	16
Parts List.....	16
Tape Head	18
Parts List.....	18

Specifications



- 🔥 **Speed:** 20 m/min
- 🔥 **Tape width:** 1- 3 inch
- 🔥 **Carton / case size:** 15cm x 12cm ~ 50cm x 50cm
- 🔥 **Machine Size:**
 - **Width:** 85cm
 - **Length:** 102cm
 - **Height:** 135cm
 - **Deck Height:** 55cm ~ 72cm
- 🔥 **Power supply:** 110V,220-240V/50-60Hz

Component Diagram

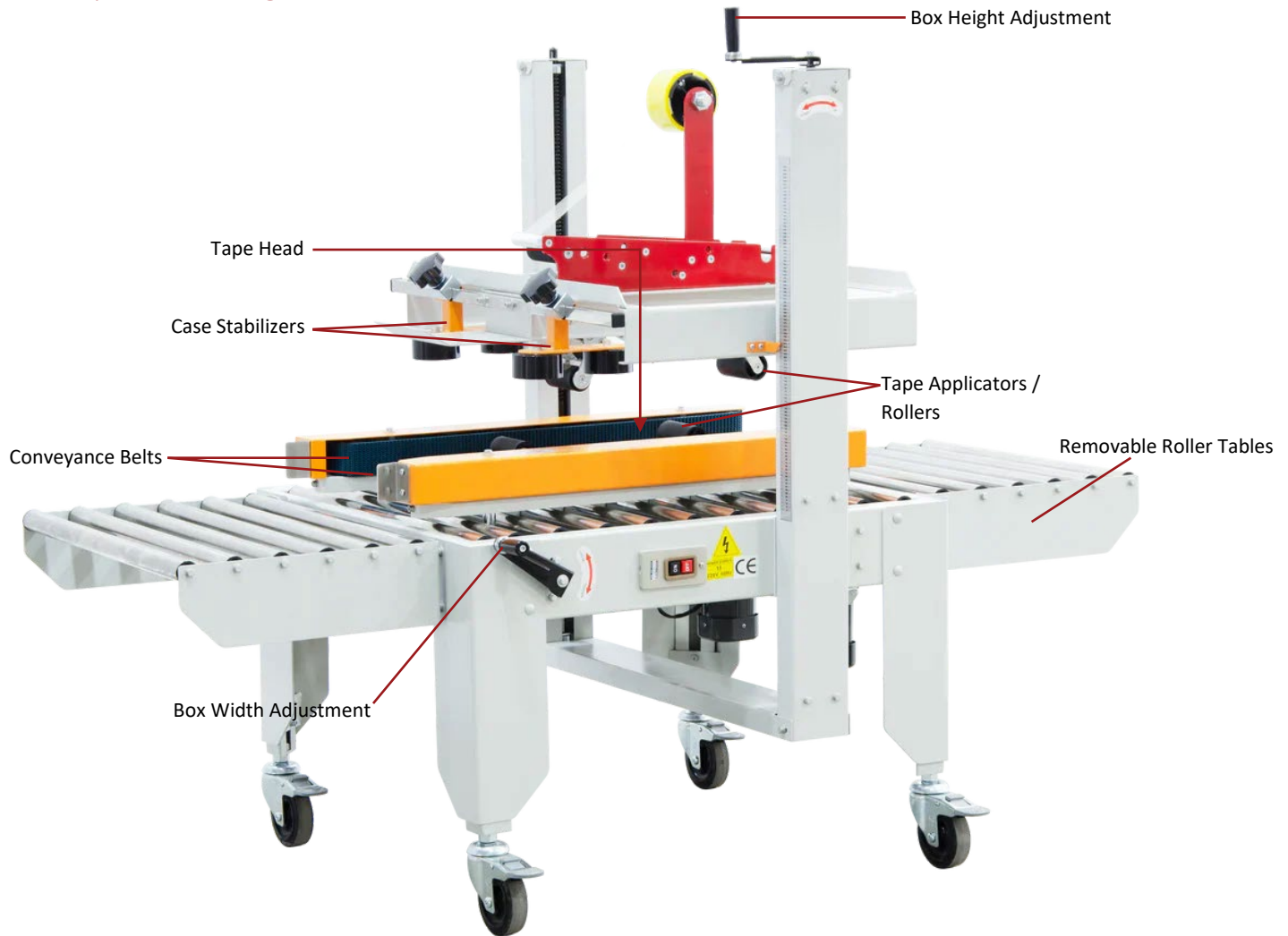

Setting up the Case Sealer

Adjusting the Deck Height

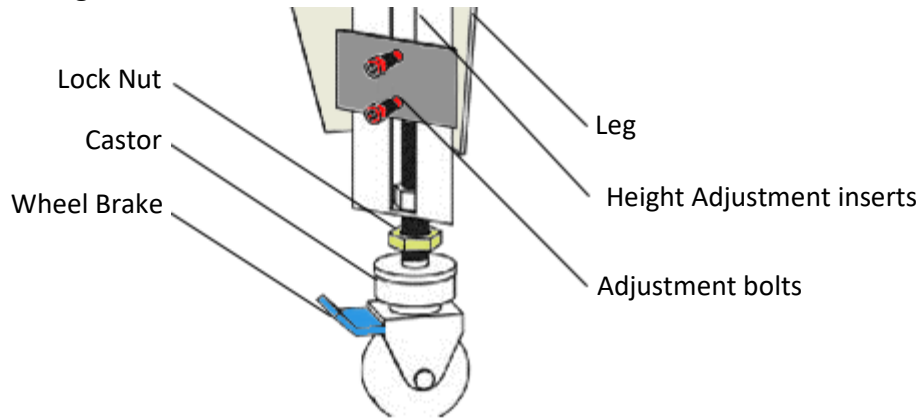
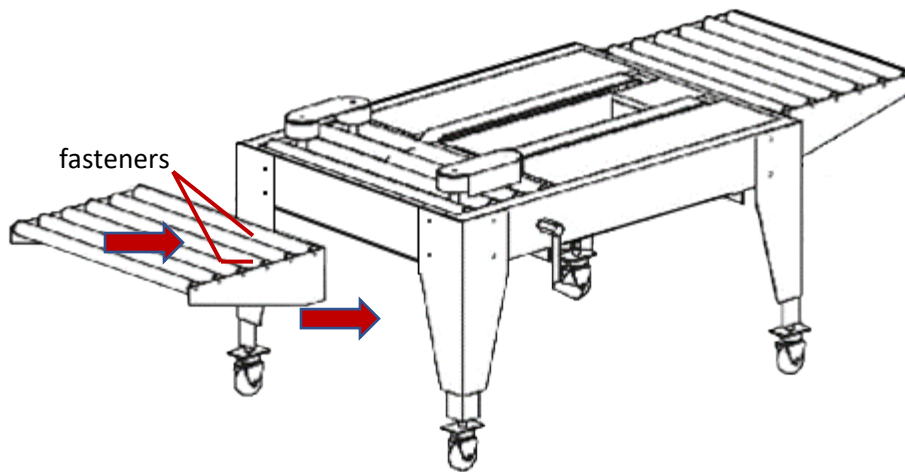

Figure 1

1. Begin by lifting the case sealer to the desired height with a pallet fork, dolly, or jack and secure it safely in place.
 2. Loosen the “adjustment bolts” on each leg and allow the “Height adjustment Insert” to drop the floor.
 3. Tighten the adjustment bolts and repeat these steps for each leg.
 4. Once you have tightened all of the legs remove the lifting device holding the case sealer in place.
- ❖ Always consider safety and never lay down underneath the case sealer while adjusting the legs.

Installing the Roller Tables

1. The fasteners (nuts) to attach the roller tables are already tightened onto their corresponding bolt and will need to be removed first. ***Only remove the first of two fasteners (nuts)**
2. Once the fasteners are removed place the roller tables onto the bolts and tighten them in place.



Adjusting for your Carton Dimensions.

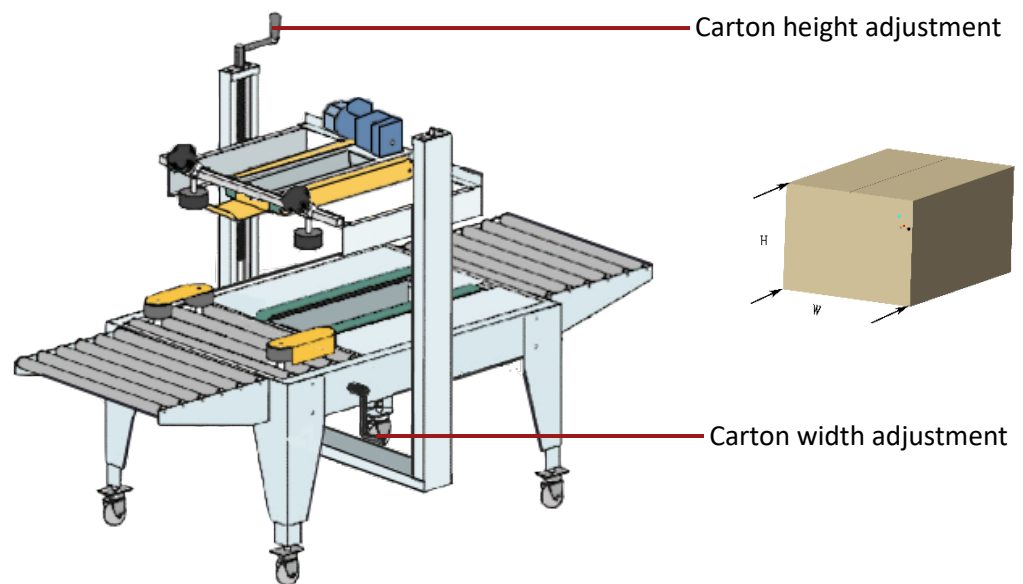
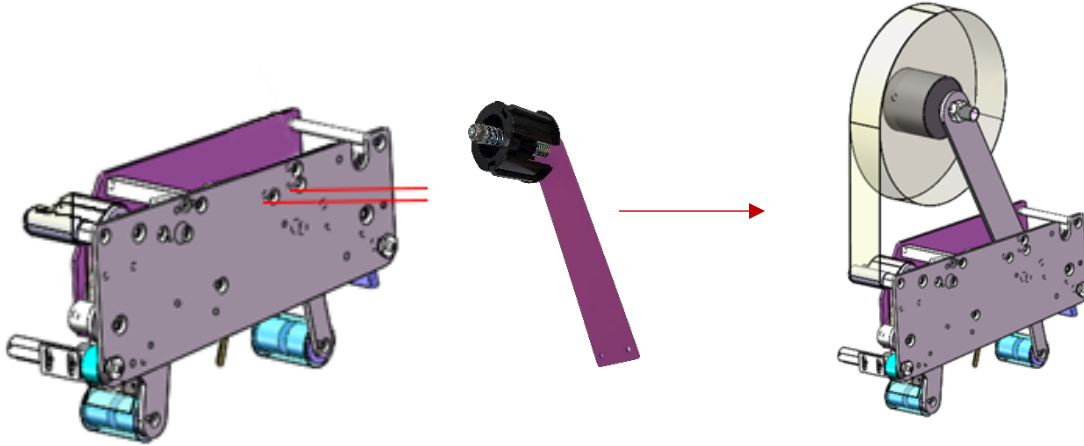

Figure 3

1. To set the case sealer to fit the dimensions of your carton/case use the adjustments shown in Figure 3.
2. The adjustment handles will be installed backwards for shipping, remove them using the included 10mm wrench and reinstall.

Installing the Tape

1. Begin by attaching the tape arms to each tape head using the included screws. (top and bottom)



2. Next Install the tape onto the tape wheel so that when you pull the tape down the adhesive side is facing outward.
3. Now guide the tape under the first guide roller, over the one-way roller, and through the clip just above the last guide roller. **The red line in figure 5 shows the tape path.**

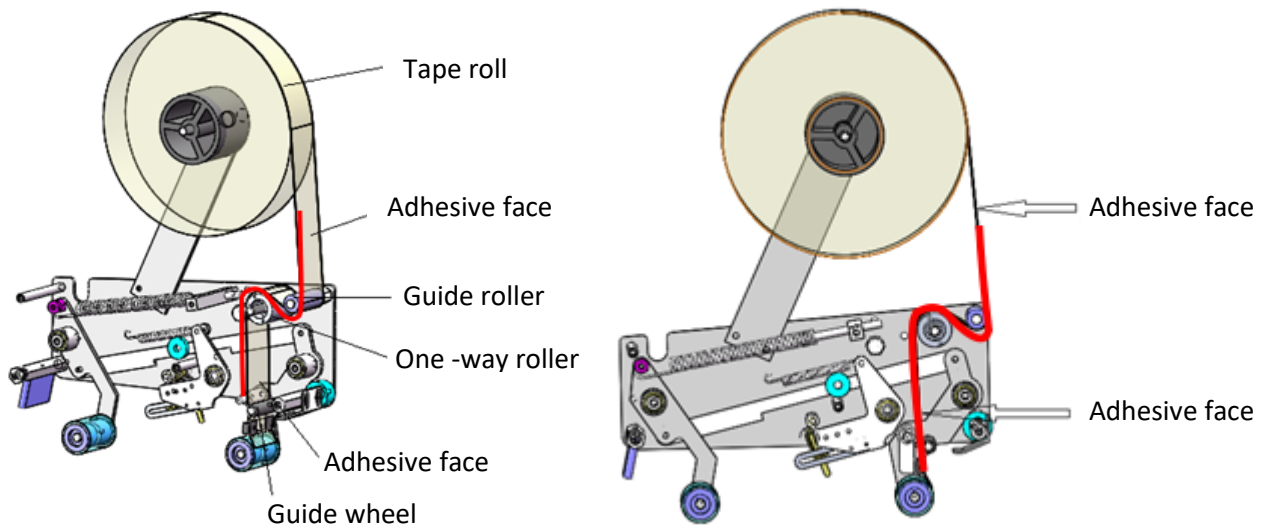

Figure 5

Adjusting the Tape Position

If you find that your tape is not lining up with the center of the box seems you can use the M18 nut shown in figure 6 to reposition the tape.

1. Remove the tape roll.
2. Loosen the nut.
3. Thread the tape spindle in or out to move the tape to the left or right on the arm.
4. Tighten the M18 nut into place when you have set the desired position.

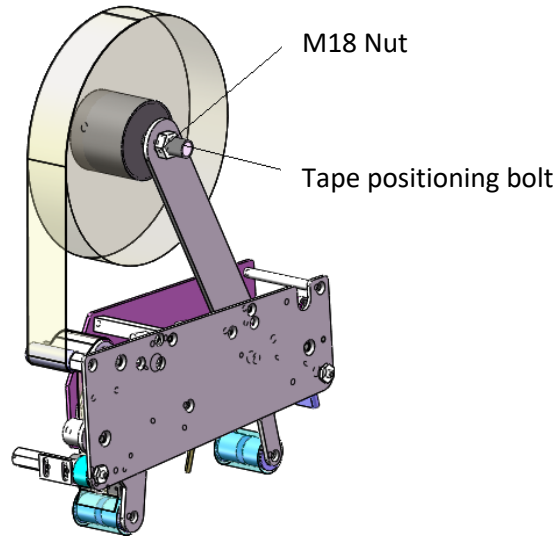
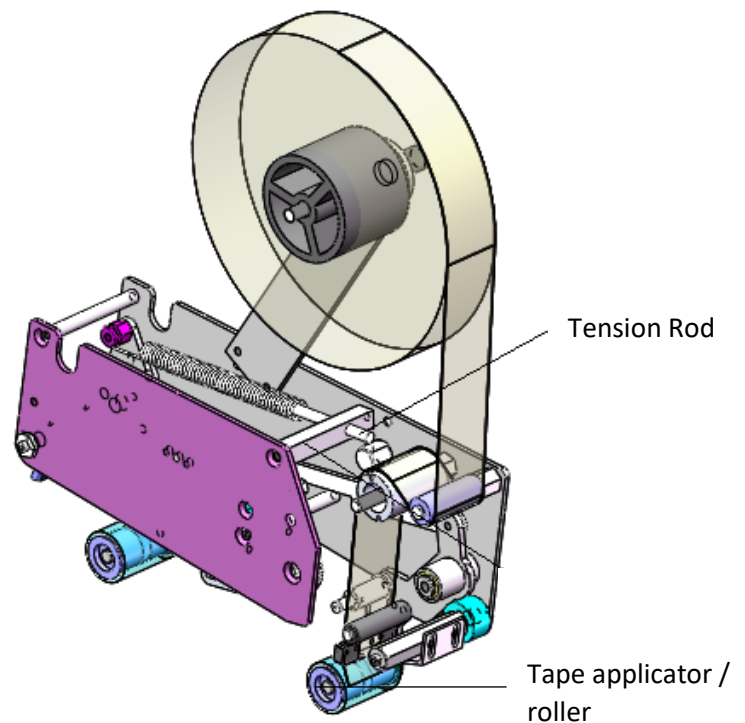

Figure 6

Setting the Tape Tension

- ✦ The tape applicators will come to you already adjusted. You may find that over time the tension needs to be adjusted.
- ✦ To loosen or tighten the tension of the tape applicators use the nut on the end of the tension rod.
- ✦ Turn the nut right to tighten the spring and to the left to loosen.



Common Issues

Issue	Cause	Solution
Tape does not cut	The tape head blade is dull or jammed	1.Remove the tape jam. 2.Wipe clean any accumulated adhesive from the tape head with 90% isopropyl alcohol. 3.Sharpen or replace the tape blade.
The tape has been cut but only applied to a section of the case/ carton	The Tape head is likely jammed	1.Remove the Jam 2.Check to see if any parts of the tape head have come loose.
The box is sealed but the flaps are loose	1.The main tension spring is too loose 2.the height adjustment is set too high.	1.Tighten the nut on the tension rod. This will stiffen the tape applicators (pg10 / fig7)
The carton gets stuck halfway through	The main tension springs are too tight causing the tape applicators to pinch the box in place	Loosen the tension spring by backing out the nut on the tension rod (Pg10/Fig 7)
The tape is retracting or coming loose from the rollers	Check to see if the one-way tape roller is spinning both ways.	Replace if needed

Circuit Diagram

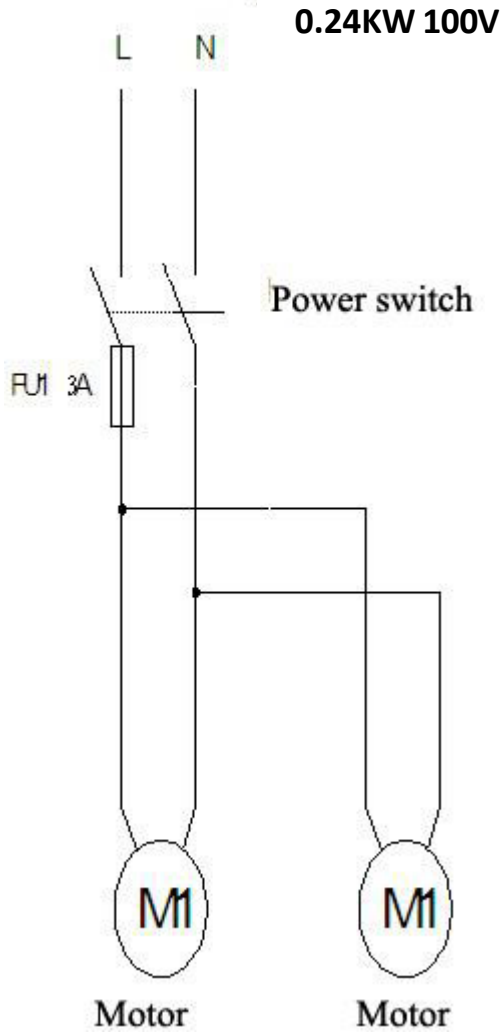

Exploded Parts Diagrams



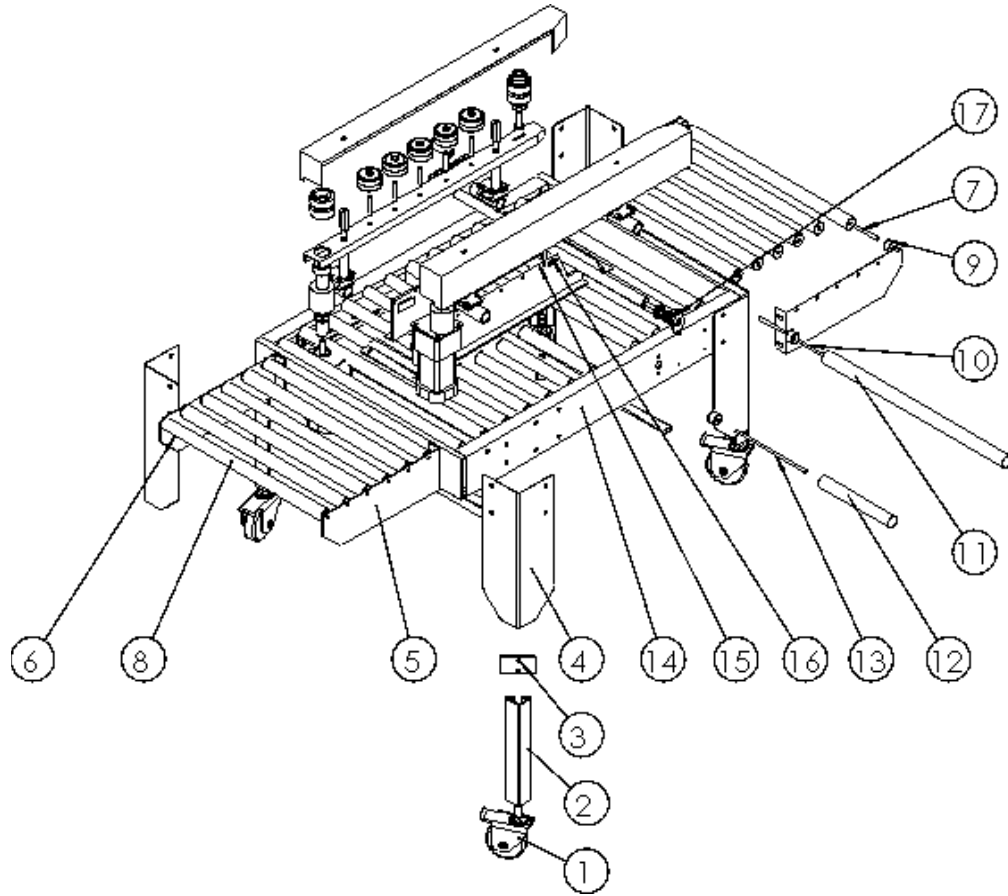



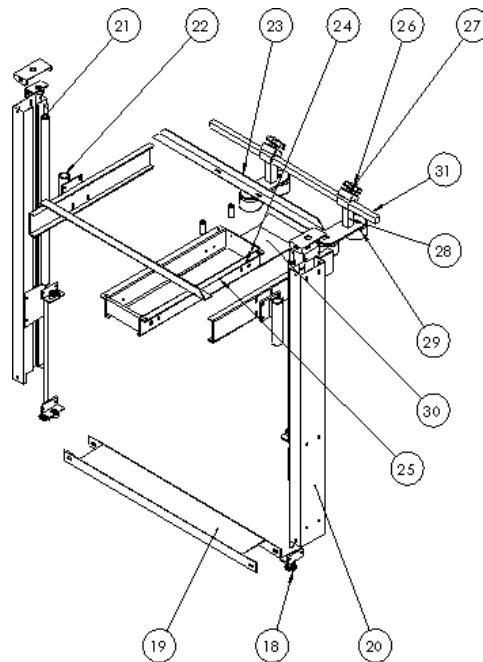





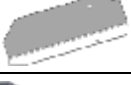



Main Body



Lift Mechanism



Parts List

ON.	DRAW	DESCRIPTION	QTY	MEMO
1		Castor	4	With stop
2		Adjust under carriage	4	
3		Solid square	4	
4		Under carriage	4	
5		Bracket	2	
6		Bracket	2	
7		Axle	12	
8		Beam barrel	12	
9		Axle sleeve	62	
10		Axle	7	
11		Beam barrel	7	
12		Beam barrel	12	
13		Axle	12	
14		Frame	1	
15		Catch plate	2	
16		Pin	7	
17		Chain	1	





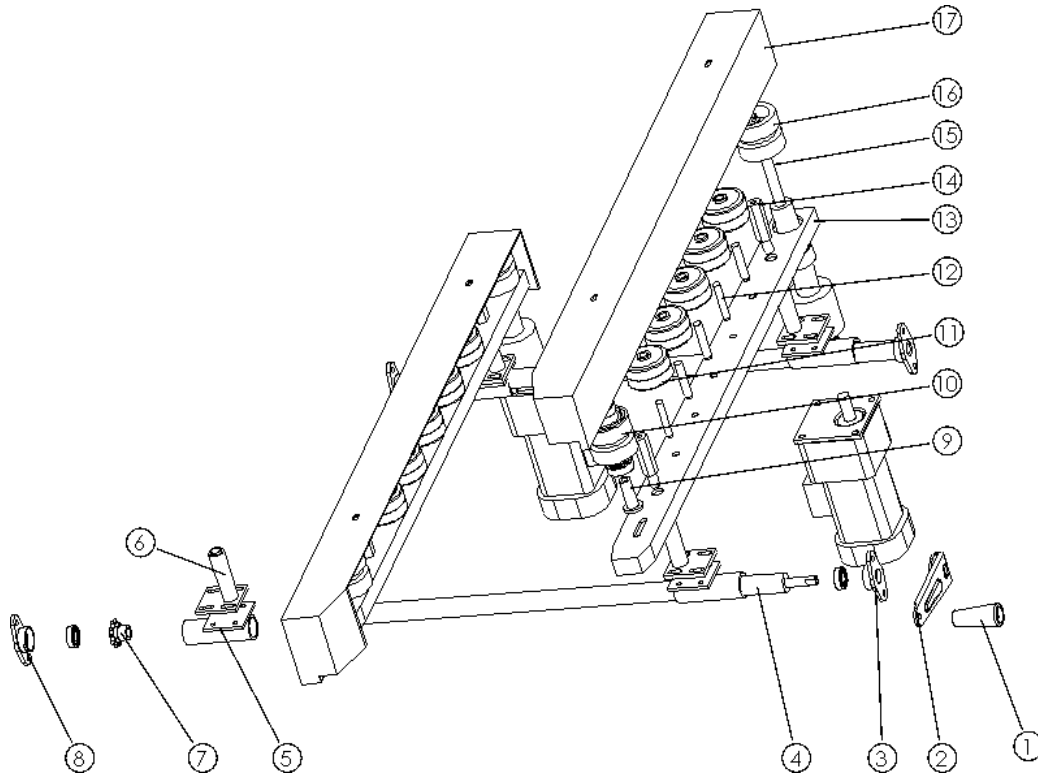







18		Chain wheel	2	
19		Cover plate	1	
20		Upright column	2	
21		Axle	2	
22		Axle sleeve	2	
23		Bracket	1	
24		Catch plate	2	
25		Bracket	1	
26		Start handle	2	
27		Lock block	2	
28		Clamping roller lever	2	
29		Clamping roller	4	
30		Guide plate	1	
31		Adjuster lever	1	

Drive / Conveyance System



Parts List

ON	DRAW	DESCRIPTION	QTY	MEMO
1		Handle	1	
2		Handle setting shaft	1	
3		Unit bearing assembly	2	
4		Screw rod	2	
5		Sliding base	4	

6		Belt bracket	4	
7		Chain wheel	2	
8		Unit bearing block	2	
9		Pin roll	2	
10		Driven wheel	2	
11		Idle wheel	20	
12		Single port idle shaft	10	
13		Belt bracket	2	
14		Belt cover support bar	4	
15		Drive axle	2	
16		Drive wheel	2	
17		Belt cover	2	

Tape Head

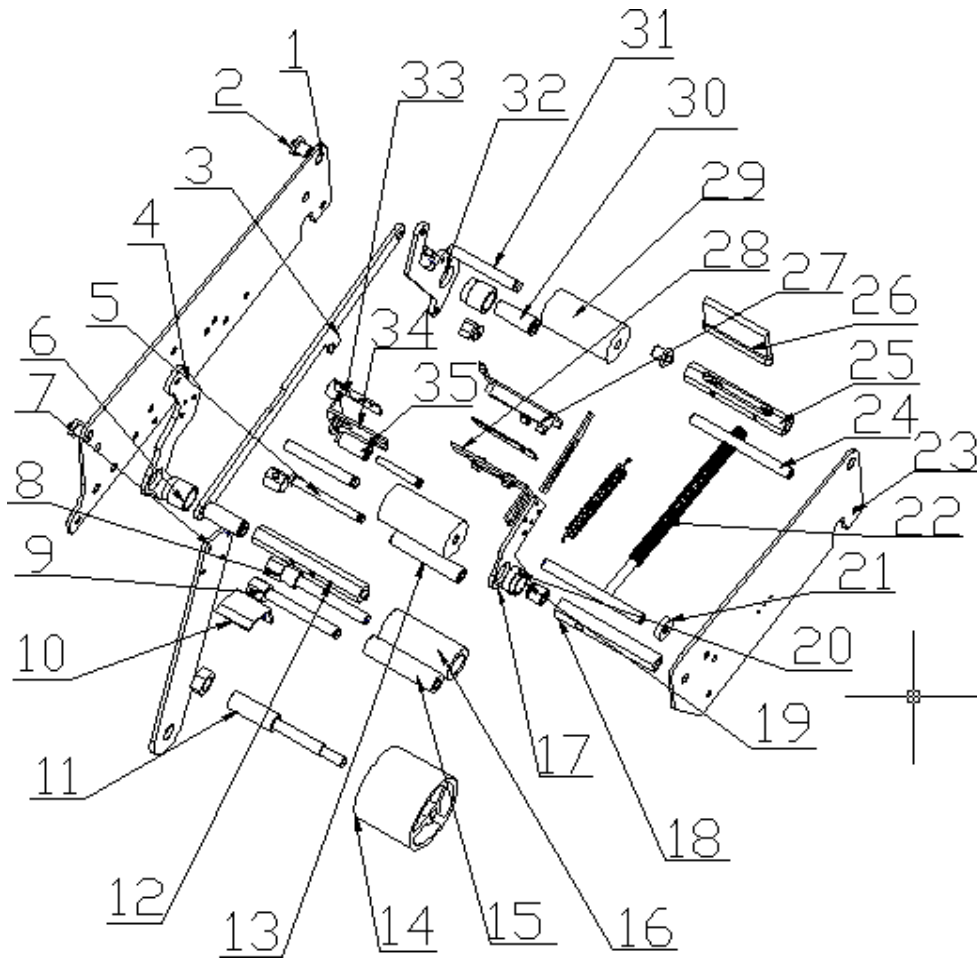

Parts List

No.	Description	QTY	MEMO
1	Left panel	1	
2	Hexagon shaft	1	
3	Connection link	1	
4	Front swing	1	
5	Knurling guide roller axle	1	
6	Stationary axle sleeve	2	
7	Adhesive tape supporting arm	1	
8	Unidirectional guide roller axle	1	

9	PE roller axle	1	
10	Front guide board	1	
11	Adhesive tape holder stationary axle	1	
12	Front support axle	1	
13	Knurling guide roller	1	
14	Adhesive tape roller	1	
15	PE roller	1	
16	Unidirectional knurling roller	1	
17	Cutter holder wedding board	1	
18	Main spring lock shaft	1	
19	Cutter holder stationary axle	1	
20	Cutter holder stationary axle sleeve	1	
21	Baffle roller	2	
22	Main spring	1	
23	Right panel	1	
24	Panel lock axle	2	
25	Brush lock axle	1	
26	Brush	1	
27	Cutter cover	1	
28	Bracket	1	
29	Back glue roller	1	
30	Stationary axle	2	
31	Glue roller axle	2	
32	Rear swing	1	
33	Top-plate	1	
34	Adhesive supporting bracket	1	
35	U-shape axle sleeve	1	