SNEED PACK

CS-56 TB



TOP AND BOTTOM BELT DRIVEN CARTON
SEALER

Contents

Product Introduction	2
The main technical parameters of the machine	2
The main components of the machine	3
Installation of the machine	4
Machine Debugging	5
Width adjustment	5
Height adjustment	5
Operation and adjustment of tape dispenser	6
Common malfunctions and trouble-shooting methods:	7
Operation sequence of the machine	8
Common malfunctions and trouble-shooting methods	9
Drawing of electric control principle	11
Exploded diagram of tape dispenser	12
Wearing parts list of tape dispenser	12
Exploded diagram of machine frame	14
Parts list of Machine frame	15
Exploded diagram of lifting system	16
Parts list of lifting system	17
Exploded diagram of drive system	18
Parts list of drive system	19

Product Introduction

The GPB-56 Top and Bottom Belts Driven Carton Sealer is used for sealing top and bottom covers. It can be used independently or in packing line. Now, the machine is widely used in industries like family electric appliance, textile, food, medicine, chemical industry, etc. The carton sealer uses adhesive tape for sealing cartons, with the advantages of economical, fast, and easy to adjust. The top and bottom sealing can be finished simultaneously. By sealing with printed tape, it can greatly promote products' image. This machine is durable in use, convenient in operation and easy in installation and debugging. The adjustment of width and height is also very easy.

The main technical parameters of the machine

Model	GPB-56
Conveying speed	0-20m/min
Max. Packaging Size	W500×H600mm
Min. Packaging size	W150×H110mm
Power supply	110V,220-240V/50-60Hz
Power	180W
Tape width	1" 2" 2.5"
Machine size	L1660×W740×H1590mm
Machine weight	145Kg
Working table height	700mm

Notices:

- ① Don't use the carton with plastic film on the surface.
- ② The carton must be dry. (Wet carton can't be sealed)
- ③ No dust and garbage are allowed on the surface of the carton
- ④ Deformed cartons are prohibited for use. Carton blanks with ripples on

the sealing are not suitable for sealing.

- ⑤ Deformed tape can not be used.
- ⑥ Cloth tape are not allowed for use.
- ⑦ Tape with uneven width and thickness or burrs can not be used.
- ⑧ Tape that produced for half year is not suggested for use.

The main components of the machine

As illustrated in the below drawing, the carton sealer is mainly composed of frame work, bottom tape dispenser, top tape dispenser, lifting system, motor system.

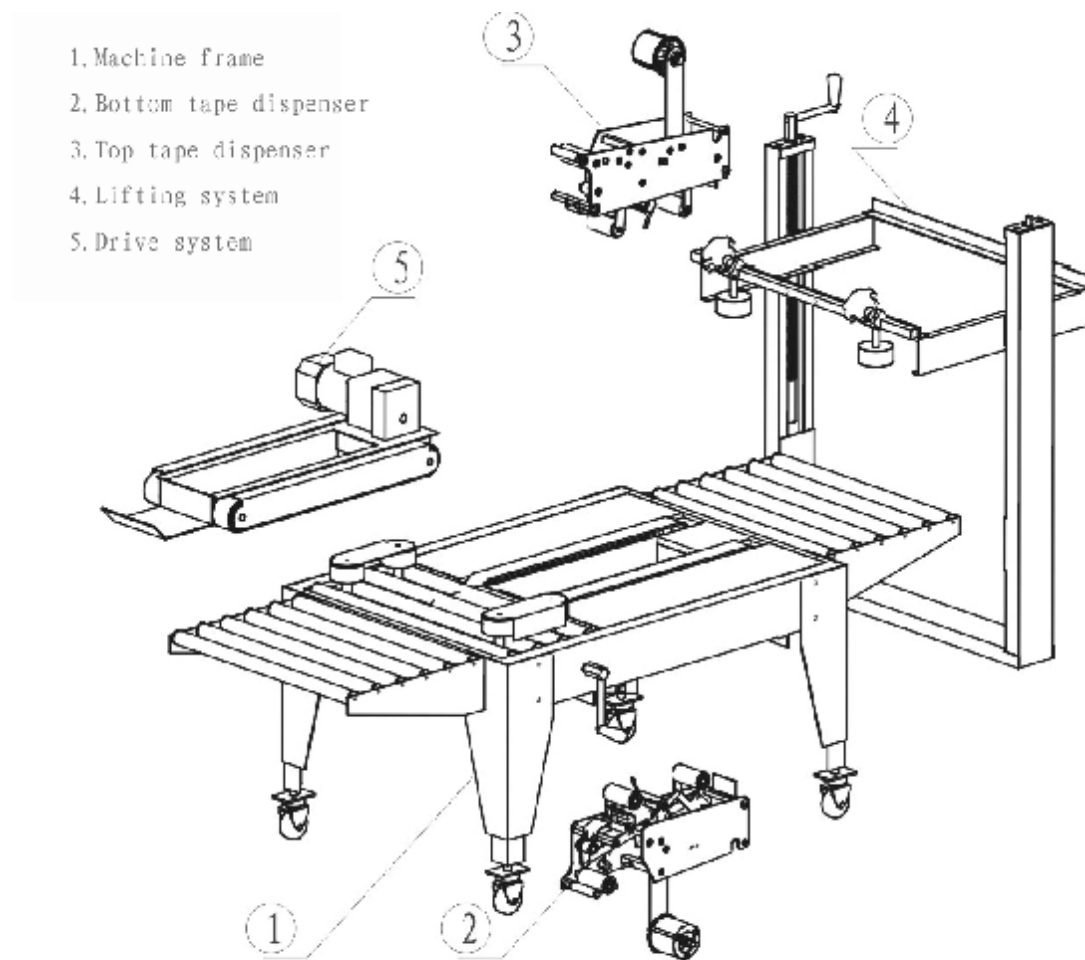

Exploded Diagram of Carton Sealer

Installation of the machine

Installation and trial run of the machine should be completed before use.

- ① Install the machine in the working place and adjust the height of the supporting foot until the working table's height meets requirements. Then adjust the height and levelness of the working table slightly until it meets requirements and press down the lockers of the four castors for fixing the frame work.
- ② Connecting the power supply.(220V 50Hz)
- ③ Connecting the air supply.(0.5-0.7MPa)
- ④ Adjusting the size of the conveying route for suiting conveying cartons.

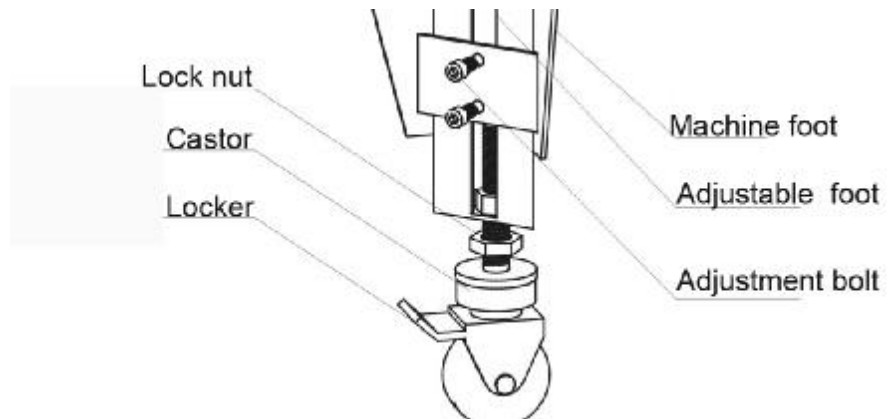

- ⑤ Install the conveying roller table. Hang it on the hooks.

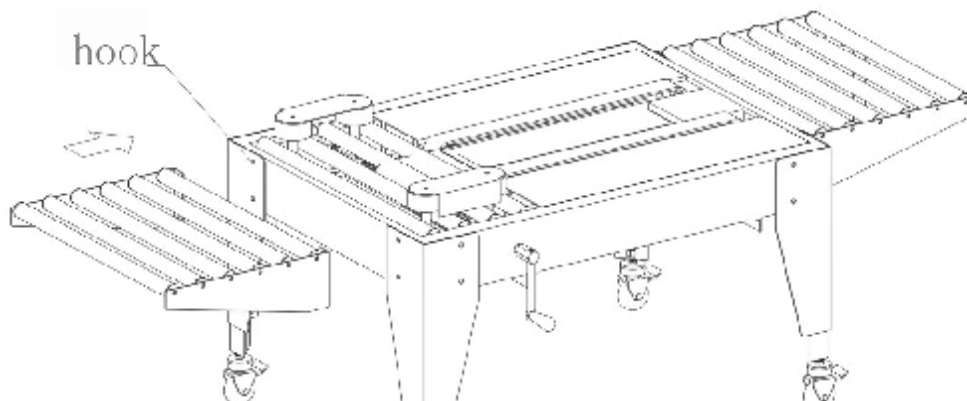

Machine Debugging

Width adjustment

- a. Adjusting the spacing between top & bottom guidance wheels for suiting the width of the cartons. The position of sealing would have deviation if the spacing of the guidance wheels is not suitable.
- b. Put carton on the working table, release the adjustment knobs and move the guidance wheel to the sides of cartons and fix the knobs.
- c. Put carton on the working table, shake the adjustment handle to make the guidance wheel pressing on the sides of carton.

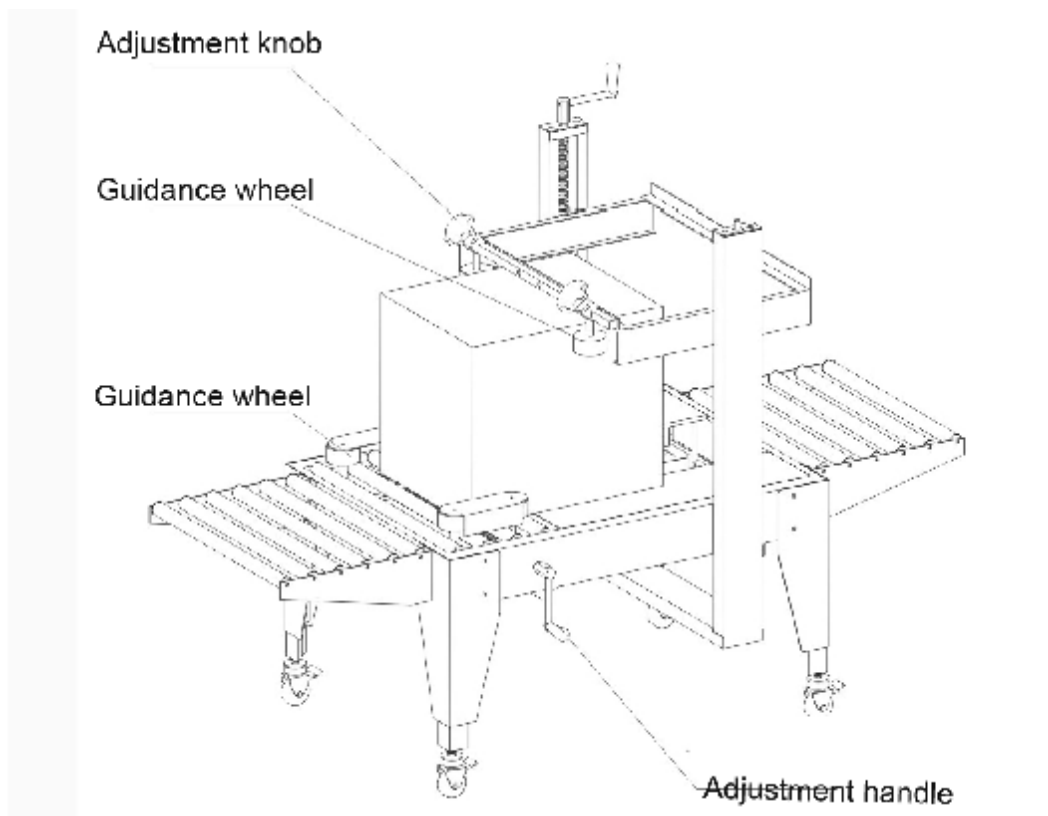

Height adjustment

Shake the height adjustment handle until the tape dispenser a bit higher than the height of the carton. Put carton on the working table and shake

handle to fix it at a suitable height at which conveyor belts can clamp and convey the carton.

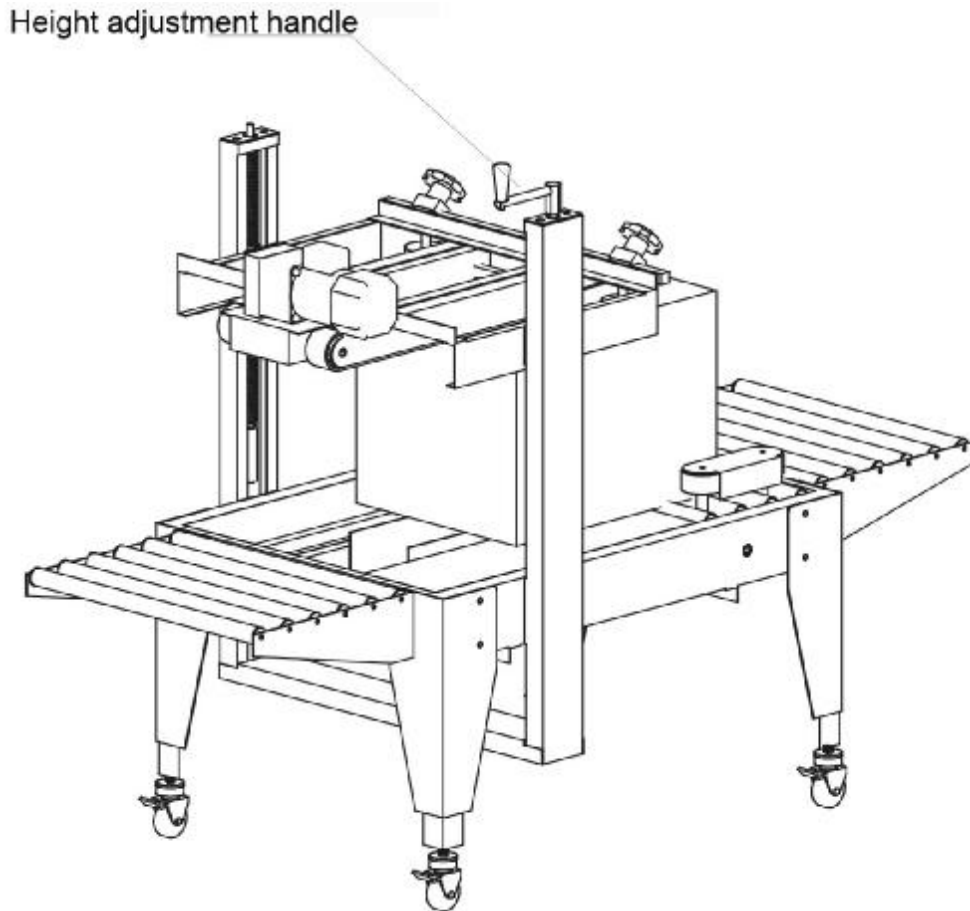

Operation and adjustment of tape dispenser

- a. At first, install the roll of OPP adhesive tape at the core axis (see the drawing below), pull out the adhesive tape and circle around roller C, then circle around roller B, D, get through tape seat E and get out of the front side of roller F. Pay highly attention that the side with glutinosity should face toward outside.

- b. Drawing of the adhesive tape threading

c. Adjustment of the position of tape

If the tape is not on the middle line of carton, you can adjust it according to drawing blow: loose the nut B and adjust the core axis with screwdriver so that the position of tape can be adjusted.

d. Adjustment of tape's tension

Turn the knob, loosen the nut M8, and adjust the bolt M8*50 to change the elasticity of swing-rod long extension spring so as to control the tape's tension..Turn the knob clockwise and the tension of adhesive tape will be larger; turn the knob anticlockwise, and the tension of adhesive tape will lessen. when the bolt M8*50 is adjusted forward, the strain of adhesive tape will be larger; conversely, the strain of adhesive tape will lessen.

Common malfunctions and trouble-shooting methods:

NO.	Malfunction	Possible causes	Solution
1	Adhesive tape can not be cut off.	The cutter blade is not sharp enough. The blade is jammed by the adhesive.	Change the cutter blade. Wash and clean the blade.
2	There is tail after the adhesive tape is cut off.	The tape seat is deposited by adhesive. The pulling spring is too loose.	Check if the nut on the tape seat is too loose or not. Adjust the tension of spring.
3	The adhesive tape can't seal the carton completely.	Main spring is too loose and there is adhesive on the axis of the roller.	Adjust the tension of main spring and clear up the roller.

4	The carton is jammed in the midway.	The main spring is too tight.	Loosen the main spring.
5	The tape falls down frequently.	The single roller can't work.	Change for a new one
6	Carton is deformed after sealing.		Side flaps should be folded flatly before sealing.
7	There are wrinkles on the tape after sealing.		As illustrated in, adjusting the Nut M8 for increasing the tension.

Operation sequence of the machine

A. Install tapes on the top and bottom tape dispenser

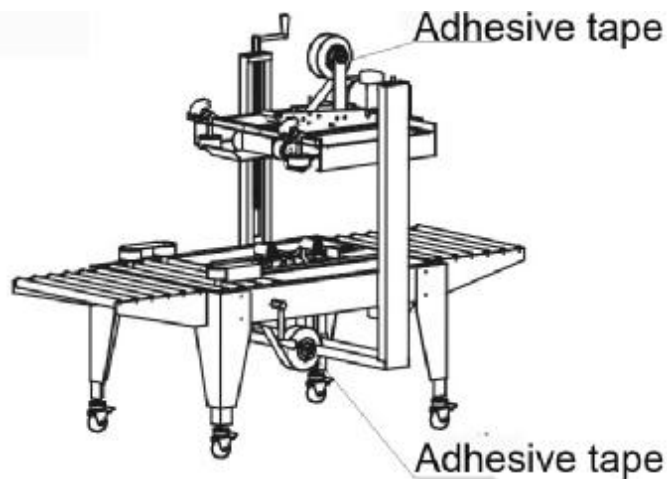

B. Adjustment the width guidance wheel

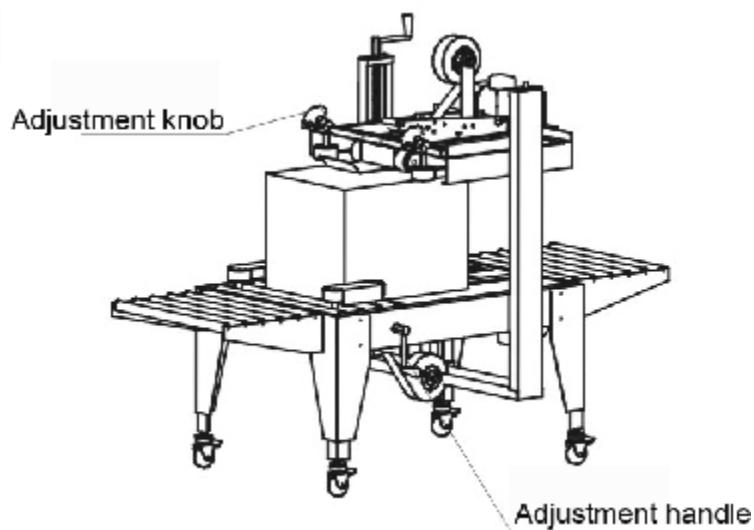

C. Adjust the height of conveyors

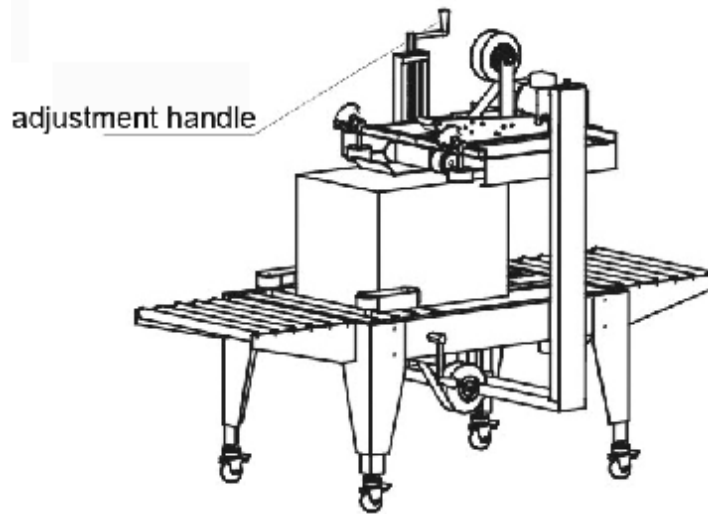

Common malfunctions and trouble-shooting methods

NO.	Malfunction	Possible causes	Solution
1	Adhesive tape can not be cut off.	The cutter blade is not sharp enough. The blade is jammed by the adhesive.	Change the cutter blade. Wash and clean the blade.
2	There is tail after the adhesive tape is cut off.	The cutter blade is not sharp enough. The tape seat is deposited by adhesive. The pulling spring is too loose.	Check if the nut on the tape seat is too loose or not. Lubricate the nut if necessary.
3	The adhesive tape can't seal the carton completely.	Main spring is too loose and there is adhesive on the axis of the roller.	Adjust the tension of main spring and clear up the roller.
4	The carton is jammed in the midway.	The nut on the tape wheel is too tight. The height of the conveyor belts is not suitable. The main spring is too tight.	Loosen the tape wheel and adjust the nut. Adjust the height. Loosen the main spring.

5	The adhesive tape is cut off during sealing process.	The cutter blade holds out too long.	Lower the cutter blade.
6	The adhesive tape is often off the track.	The pressure generated by the guiding roller on the carton is not even.	Adjust the spacing of the guiding roller.
7	The adhesive tape is not on the central line.	The anti-reverse wheel is broken.	Change the anti-reverse wheel..
8	Abnormality occurs during the sealing.	There is dust on the axletree seat.	Clean the axletree seat and lubricate it.
9	There is jut before sealing and drape after sealing.	The speed of conveyor belts is inconsistent, and the carton is not at the proper place when pushing into the machine.	Adjust each belt's tension to be consistent . Put the carton in the right position.

If tape folds, turn the bolt A clock wisely until it move downward.

Notices: a. The machine should be power off before maintenance.

b. Blades should be cleaned and lubricated before use.

c. The tension of belts should be adjusted after using for a certain time.

Drawing of electric control principle

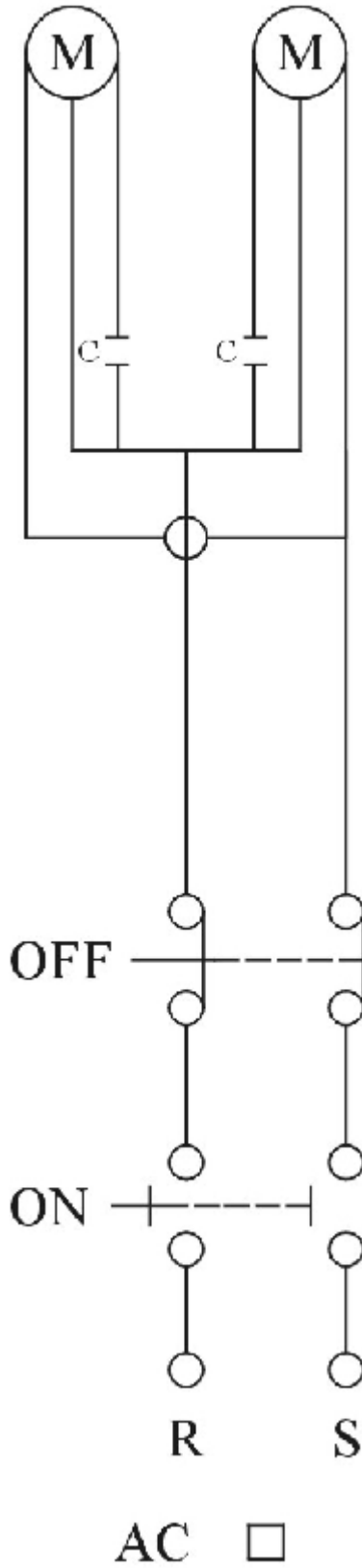

Exploded diagram of tape dispenser

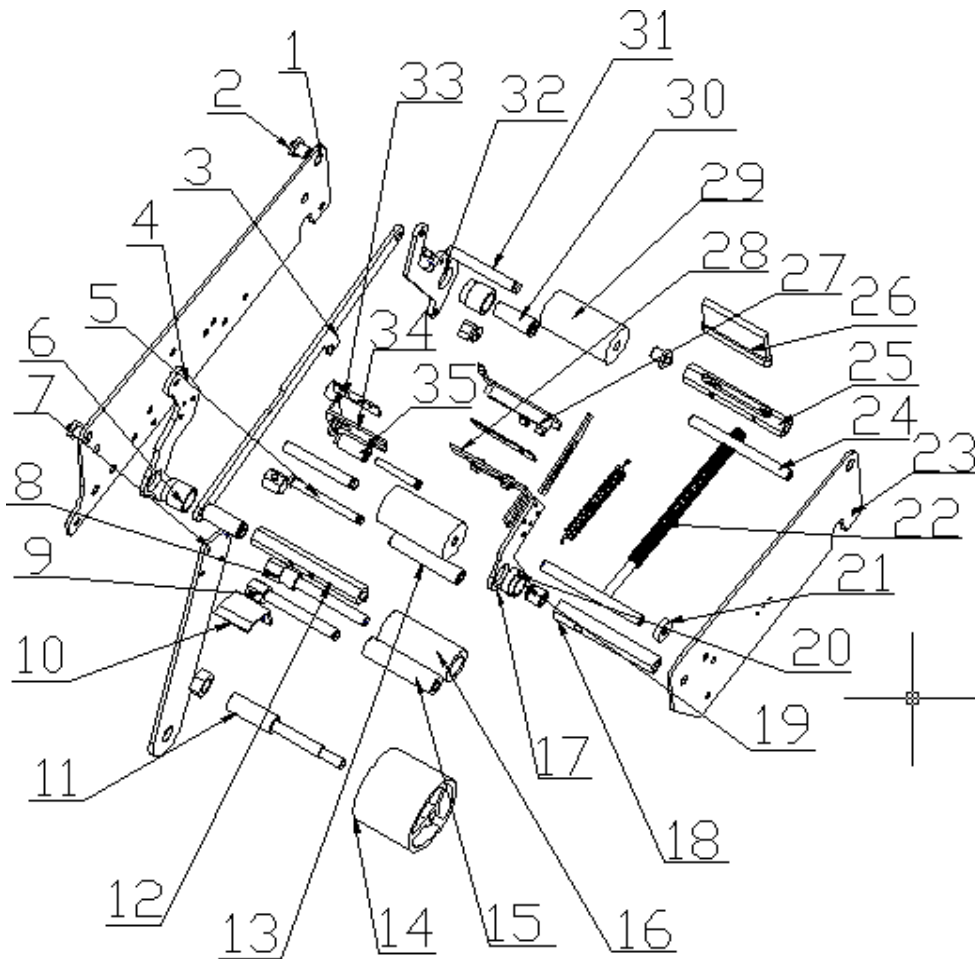

Wearing parts list of tape dispenser







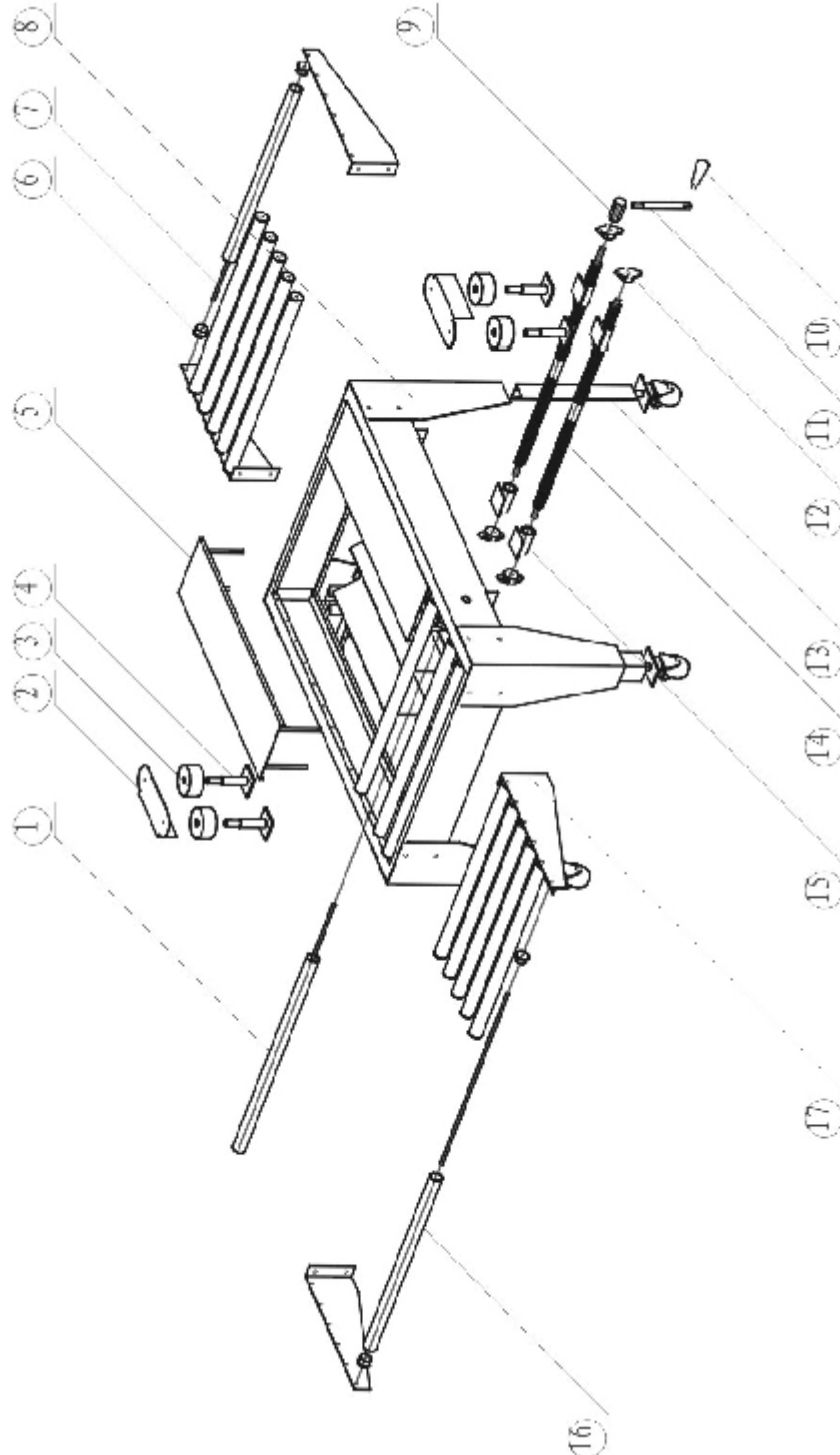







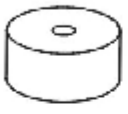

No.	PART NO.	Description	QTY	MEMO
1	TD001	Left panel	1	
2	TD002	Hexagon shaft	1	
3	TD003	Connection link	1	
4	TD004	Front swing	1	
5	TD005	Knurling guide roller axle	1	
6	TD006	Stationary axle sleeve	2	
7	TD007	Adhesive tape supporting arm	1	
8	TD008	Unidirectional guide roller axle	1	
9	TD009	PE roller axle	1	

10	TD010	Front guide board	1	
11	TD011	Adhesive tape holder stationary axle	1	
12	TD012	Front support axle	1	
13	TD013	Knurling guide roller	1	
14	TD014	Adhesive tape roller	1	
15	TD015	PE roller	1	
16	TD016	Unidirectional knurling roller	1	
17	TD017	Cutter holder wedding board	1	
18	TD018	Main spring lock shaft	1	
19	TD019	Cutter holder stationary axle	1	
20	TD020	Cutter holder stationary axle sleeve	1	
21	TD021	Baffle roller	2	
22	TD022	Main spring	1	
23	TD023	Right panel	1	
24	TD024	Panel lock axle	2	
25	TD025	Brush lock axle	1	
26	TD026	Brush	1	
27	TD027	Cutter cover	1	
28	TD028	Bracket	1	
29	TD029	Back glue roller	1	
30	TD030	Stationary axle	2	
31	TD031	Glue roller axle	2	
32	TD032	Rear swing	1	
33	TD033	Top-plate	1	
34	TD034	Adhesive supporting bracket	1	
35	TD035	U-shape axle sleeve	1	

Exploded diagram of machine frame



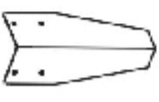

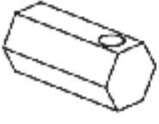



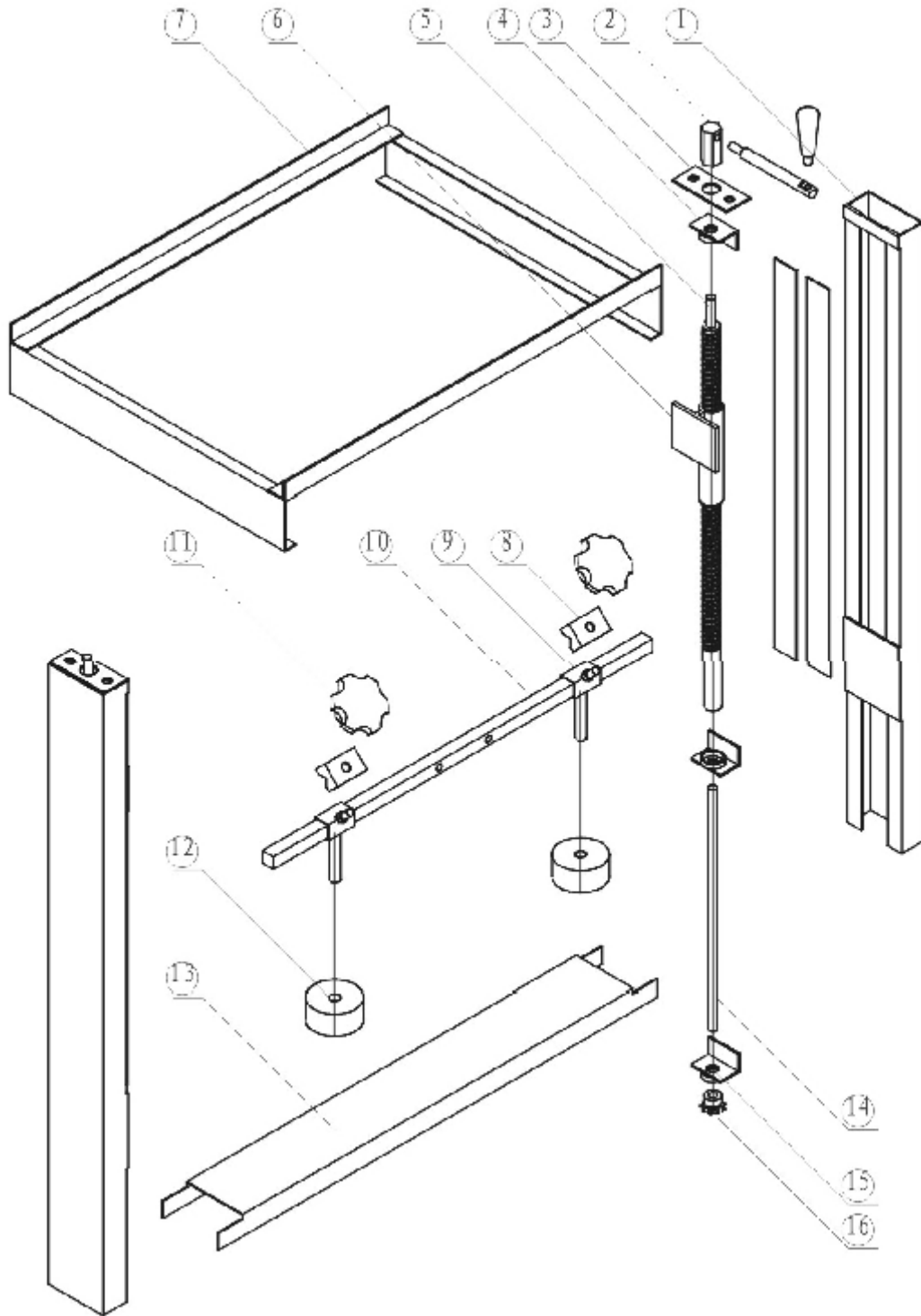





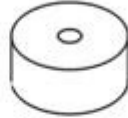

Parts list of Machine frame

	Picture	Item NO./Name	Picture	
1		A001/roller A010/handle		10
2		A002/protecting cover A011/handle bar		11
3		A003/guidance wheel A012/bearing		12
4		A004/holder A013/adjustment foot		13
5		A005/plate A014/screw rod		14
6		A006/roller sleeve A015/adjusting nut		15
7		A007/roller shaft A016/roller		16
8		A008/legs A017/support bracket		17
9		A009/handle seat		

Exploded diagram of lifting system









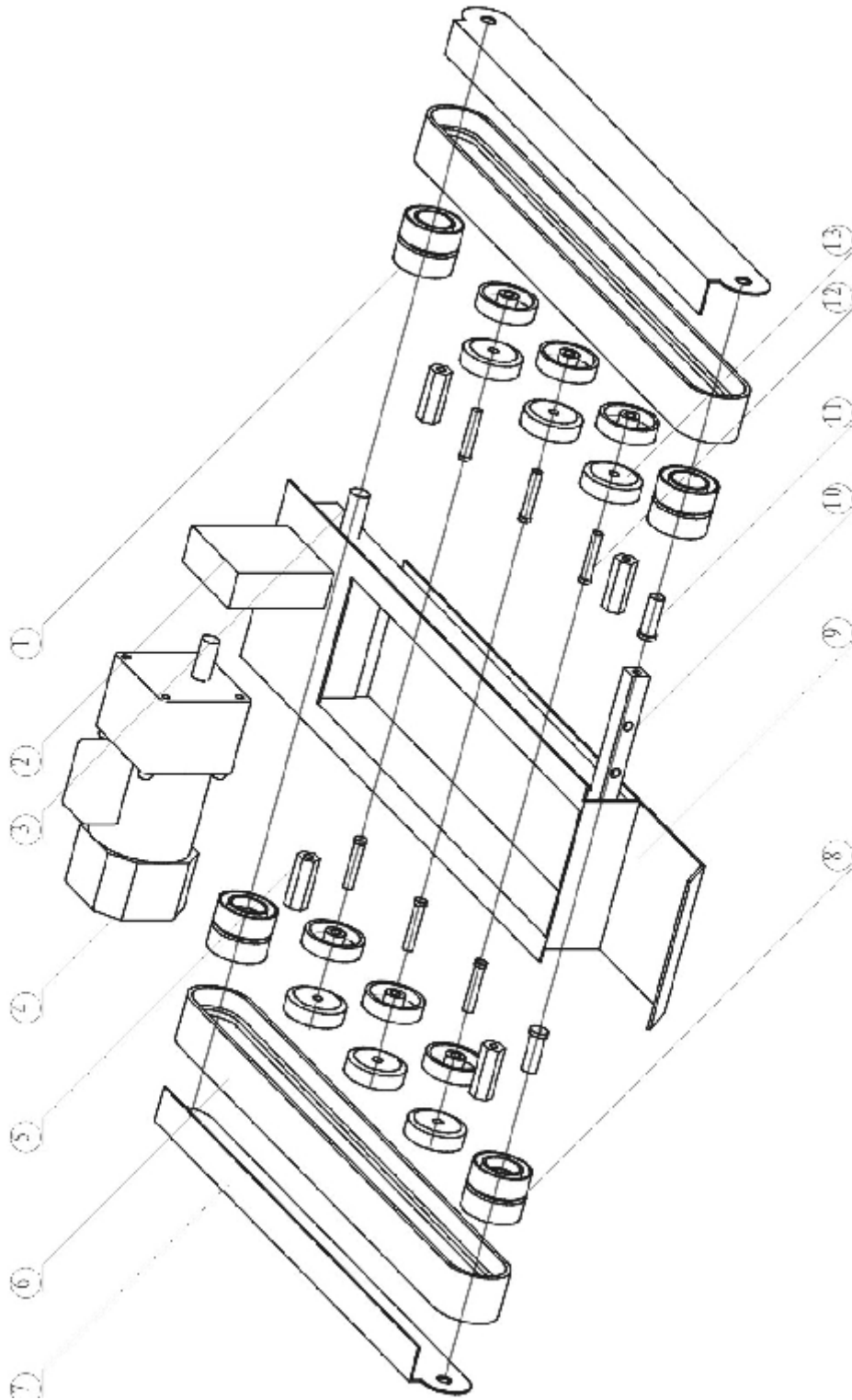



Parts list of lifting system

	Picture	Item NO./Name	Picture	
1		C001/pillar C010/beam		10
2		C002/handle seat C011/knob		11
3		C003/cover platel C012/guidance wheel		12
4		C004/guidance whee C013/sprocket wheel cover		13
5		C005/lifting screw rod A014/axletree		14
6		C006/cover of lifting screw rod C015/bearing block		15
7		C007/lifting frame C016/synchronous sprocket wheel		16
8		C008/pressing block		
9		C009/support pillar		

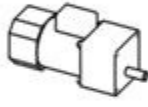
Exploded diagram of drive system

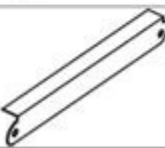

Parts list of drive system

	Picture	Item NO./Name	Picture	
1		D001/driving wheel D010/beam		10
2		D002/frame D011/lock shaft		11
3		D003/roller D012/ lock shaft		12
4		D004/motor reducing D013/guidance wheel		13
5		D005/pillar		
6		D006/conveyor belts		
7		D007/protecting cover		
8		D008/driven wheel		
9		D009/guidance plate		

